



2019 CHEVROLET SILVERADO 2WD CREW CAB

(Must use 18" or larger wheels)

Thank you for being selective enough to choose our high quality BELLTECH PRODUCT. We have spent many hours developing our line of products so that you will receive maximum performance with minimum difficulty during installation

Note: Confirm that all of the hardware listed in the parts list is in the kit. **Do not** begin installation if any part is missing. Read the instructions thoroughly before beginning this installation.

Warning: **DO NOT** work under a vehicle supported by only a jack. Place support stands securely under the vehicle in the manufacturer's specified locations unless otherwise instructed.

Warning: **DO NOT** drive vehicle until all work has been completed and checked. Torque all hardware to values specified.

Reminder: Proper use of safety equipment and eye/face/hand protection is absolutely necessary when using these tools to perform procedures!

Note: It is very helpful to have an assistant available during installation.

RECOMMENDED TOOLS:

- Properly rated floor jack and six (6) support stands
- Wheel chocks
- 1/2" drive torque wrench up to 200 ft/lbs range
- Standard and Metric socket wrench set
- Standard and Metric wrench set
- Tape measure
- Pliers
- Steel construction square
- Medium weight ball peen hammer/ center punch
- Marking pen
- Safety Glasses

1) KIT PREPERATION

- a) Open the hardware kit and remove all of the contents. Refer to the parts list (Page #) to verify that all parts are present.
- b) Park the vehicle on a smooth, level concrete or seasoned asphalt surface and activate the parking brake. Block the REAR wheels of the vehicle with appropriate wheel chocks; making sure the vehicle's transmission is in 1st gear (manual) or " Park" (automatic).

! It is very important that the vehicle is properly supported during this installation to prevent personal injury and chassis damage. Make sure that the support stands are properly placed prior to performing the following procedures. We **DOT NOT RECOMMEND** using wheel ramps while performing this installation. !

- c) Slowly lower the vehicle onto the stands and before placing the vehicle's entire weight on them. Again, check that they are properly and securely contact the chassis as described above. Check for possible interference with any lines, wires, cables, or other easily damaged components.

2) STEERING KNUCKLE REMOVAL

- a) Starting on the passenger side of the vehicle, remove the wheel from the hub assembly. Unbolt the brackets connecting the hydraulic brake line/ ABS sensor on the side of the steering knuckle and top control arm using a 10mm socket. (PHOTO 1 & 2)

(HINT: Removing the strut will allow easy installation of the steering knuckle. Using an 18mm wrench, remove the 3 top cap nuts of the strut. A 15mm socket will release the struts two mounting bolts from the lower control and allow the strut assembly to drop between the control arm. Disconnecting sway bar linkages from the lower control arms and will allow more movement when removing the steering knuckle.

- b) Remove the brake caliper assembly from the steering knuckle with an 18mm socket. Use a zip tie or wire hook ti hold the caliper to the chassis so that it doesn't dangle and damage the brake line.
- c) Using the appropriate TORX key, remove the brake rotor retaining bolt and slide the brake rotor off the hub.

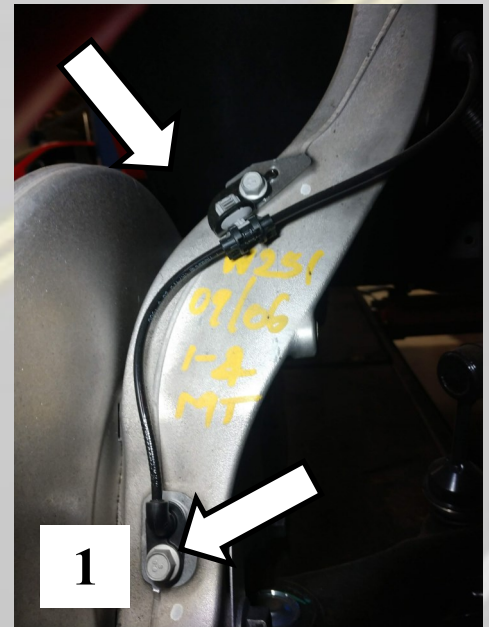

- d) Loosen the upper control arm ball joint nut with a 18mm wrench; make sure to keep the ball joint nut partially threaded on to the ball joint. This will keep the arm from swinging up and to hold everything in place while losing the remaining ball joints. Using a ball joint removal tool, free the upper control arm ball joint from the steering knuckle.
- e) Using a 21mm wrench, loosen the tire rod ball joint nut and again keep the nut partially threaded onto the ball joint, free the ball joint from the steering knuckle using the same ball joint tool.

**** !! If the coilover assembly is still installed, its helpful to use a jack or lifting device to support the lower control arm while removing the ball joints. Be very cautious when lifting the lower control arm as it is under extreme load from the spring. Make sure the lifting device base is stable and portion connected to the lower control arm is not going to slip out. !! ****

- f) Loosen the lower ball joint nut for the ball joint removal using a 24mm socket. It may be helpful to use an Allen wrench inserted in to the lower ball joint to prevent spinning.

**** !! In some cases it may be necessary to break the ball joint free from the seat in the taper. A firm, forceful strike to the upper and lower boss usually will allow the ball joint to pop free. OEM and Belltech have provided striking locations on the upper and lower bosses. (Photo 3)!! ****

- g) Remove the steering knuckle from the vehicle.

3) STEERING KNUCKLE INSTALLATION

NOTE: When using 18" wheels you must use the supplied nut and lock washer on the lower ball joint. Trim the ball joint stud for adequate clearance. (Illustration 1). The supplied lock washer and nut should be installed and torqued to 60 ft/lb. Before the ball joint stud is trimmed, it is recommended that when you remove the lower portion of the stud to leave 1/16" of the stud extended out from the nut and using a chisel or punch to score the edge of the threads to prevent any possibility of the nut coming loose (Illustration 1).

- a) Remove the three bolts on the backside of the hub assembly, disconnecting it from the OEM steering knuckle. Remove the hub assembly and backing plate (backing plate is usually associated with some aluminum steering knuckles set ups only.) (Photo 4)

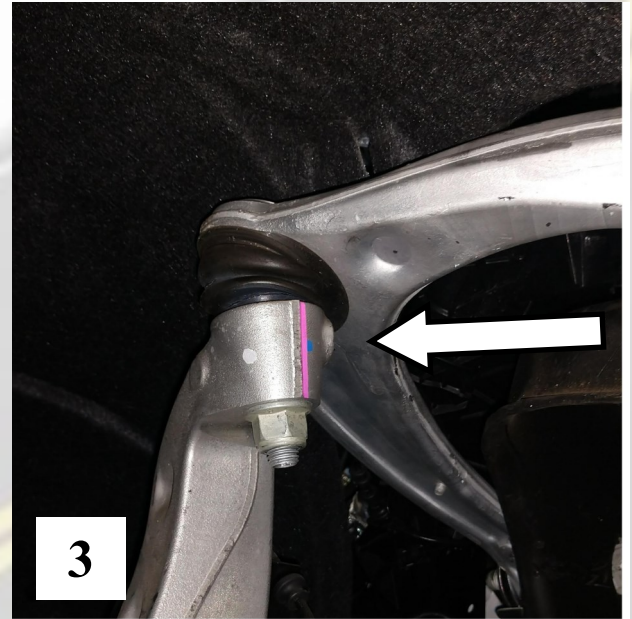

b) Re-install the hub assembly and backing plate on the Belltech steering knuckle and torque the stock hub bolts to 130 ft-lbs. (Make sure the dust plate is aligned as in OEM position.) Re use the two O-Rings from the OEM spindle and place them on the Belltech steering knuckle. **(Photo 5)**

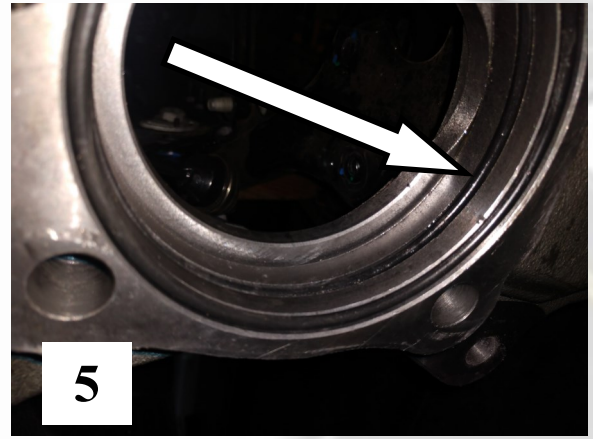

c) Attach the new steering knuckle to the upper and lower ball joints and loosely thread the nuts in place. **(Photo 6)**

! It is helpful to use a jack or lifting device to raise the lower control arm while re-attaching the spindle ball joints. Be cautious while lifting the control arm as it is under load. Make sure the lifting device base is stable and properly connected to the control arm so it does not slip out of place !

**** IF THE MOUNTING BOLTS FOR THE STRUT WERE PREVIOUSLY LOOSENED AND OR REMOVED, REINSTALL BEFORE TIGHTENING BALL JOINTS AND SWAYBAR ENDLINKS. ****

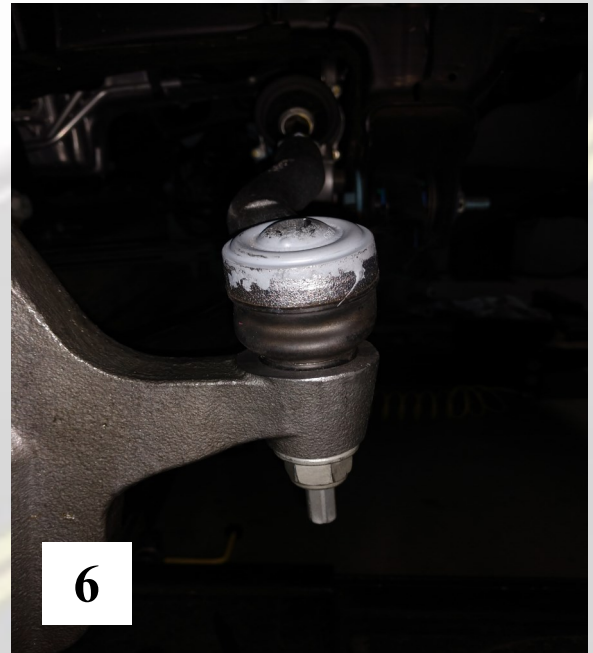

d) Tighten the upper ball joint nut in place and torque to 37 ft-lbs.

e) Tighten the lower ball joint. Torque the lower ball joint to 92 ft-lbs for the OEM nut or 60 ft-lbs for the supplied half nut.

f) Tighten the steering tie rod end of the steering knuckle and torque to 37 ft-lbs.

g) Install the ABS sensor on the side of the Belltech steering knuckle.

h) Install the disk brake onto the hub and tighten the torx bolt onto the Belltech steering knuckle.

i) Install the break caliper assembly onto the Belltech steering knuckle and torque OEM bolts to 130 ft-lbs.

j) Re-attach the brake line brackets to the side of the Belltech steering knuckle. Re-use the OEM 10mm bolts .

k) Rotate the steering knuckle left and right to full lock and confirm that the break lines cables have sufficient slack.

l) Repeat the process for the other side of the vehicle.

**** When using 18" wheel, it may be necessary to also trim some of the lower hex portion of the tie rod. DO NOT cut all the hex! ** (Photo 7)**

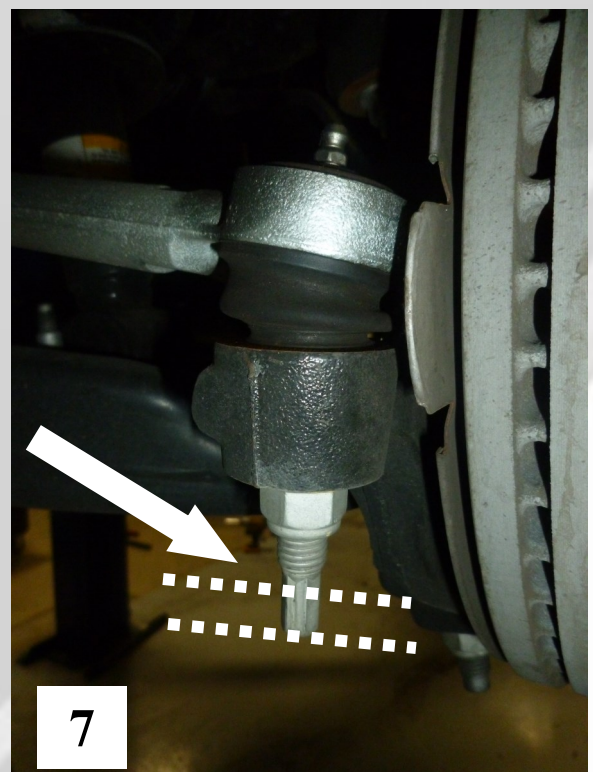

4) FINALIZING INSTALLATION

- a) Check that all components and fasteners have been properly installed, tightened and torqued.
- b) Check break hoses, and other components for any possible interference. (**Photo 8**)
- c) Reinstall both front wheels and torque lug nuts to OEM (factory) specifications.
- d) Lift the vehicle and remove stands. Carefully lower the vehicle to the ground.
- e) Test drive the vehicle in a remote location so that you can become accustomed to the revised driving characteristics and handling. Be aware that the vehicle will handle substantially different now that it has been modified.
- f) We recommend the vehicle be taken to a qualified wheel alignment facility to be realigned to factory specifications. This should be done after the vehicle has been test driven and all modifications have been completed.
- g) Installation is complete. Check ALL of the hardware and re-torque at intervals for the first 10, 100, 1000 miles

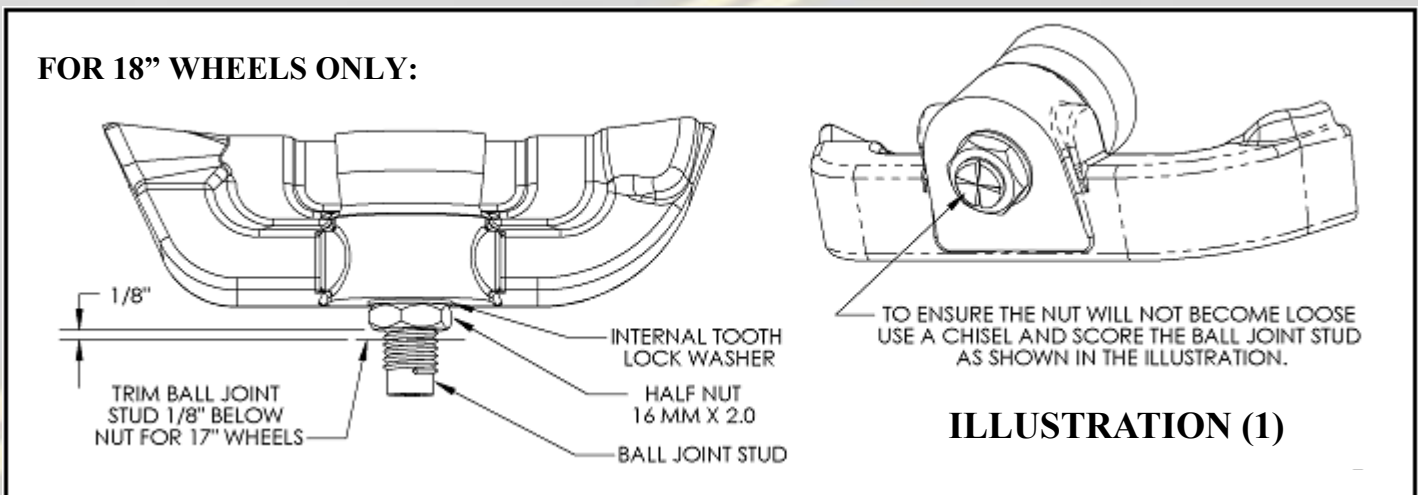
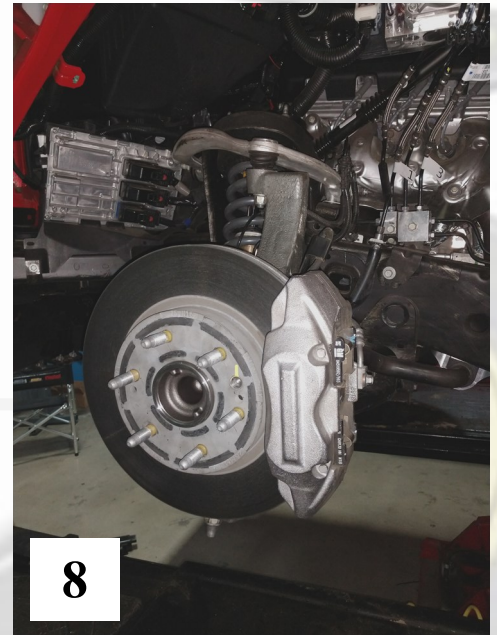

PARTS LIST		
PART #	DESCRIPTION	QUANTITY
2519-325 LH	BELLTECH STEERING KNUCKLE LEFT HAND	1
2519-425 RH	BELLTECH STEERING KNUCKLE RIGHT HAND	1
115007	HALF NUT 16mm X 2.0	2
115009	INTERNAL TOOTH-LOCK WASHER 5/8"	2