

Gen6 Quad Tip Diffuser
48-4-045

Packing List

- 1 – ACS Diffuser Panel
- 9 – U-nuts
- 9 – Short SEM screws
- 2 – Split Rivets (long)
- 2 - Templates
 - Drilling/Trimming Template
 - Drilling Template
- Instructions



Gen6 Quad Tip Diffuser
 48-4-045

Note: Read installation instructions before starting and test fit primed components before painting. Primed components are primed with an automotive grade primer, final sanding and paint is required. Painted components are clear coated, some marking from the protective bagging can be present, mild glazing will remove the marking. Always inspect parts prior to installation. To ensure the quality of your vehicle and the product have the components painted by a professional automotive paint facility. We recommend not to sand through our primer and that paint-curing temperatures not exceed 180° F.

1. Observe proper precautions and safety procedures while performing the following:

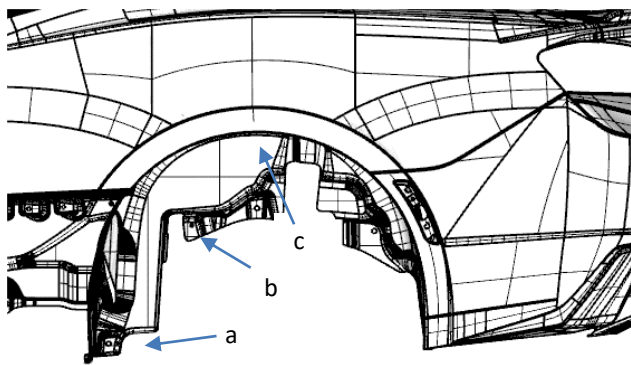

2. Raise the rear of the vehicle to a proper working height.
3. Remove the rear wheels.
4. Remove the rear wheel liners fasteners:
 - a. 2 Retainers
 - b. 3 Screws
 - c. 3 Retainers
 - d. 5 Liner Screws
 - e. 3 Bumper Fascia Bolts
5. Remove the liner.

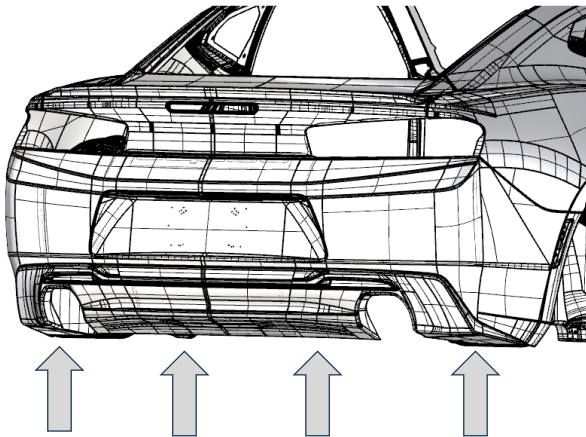

6. Remove the 8 lower rear fascia screws.

Gen6 Quad Tip Diffuser
48-4-045

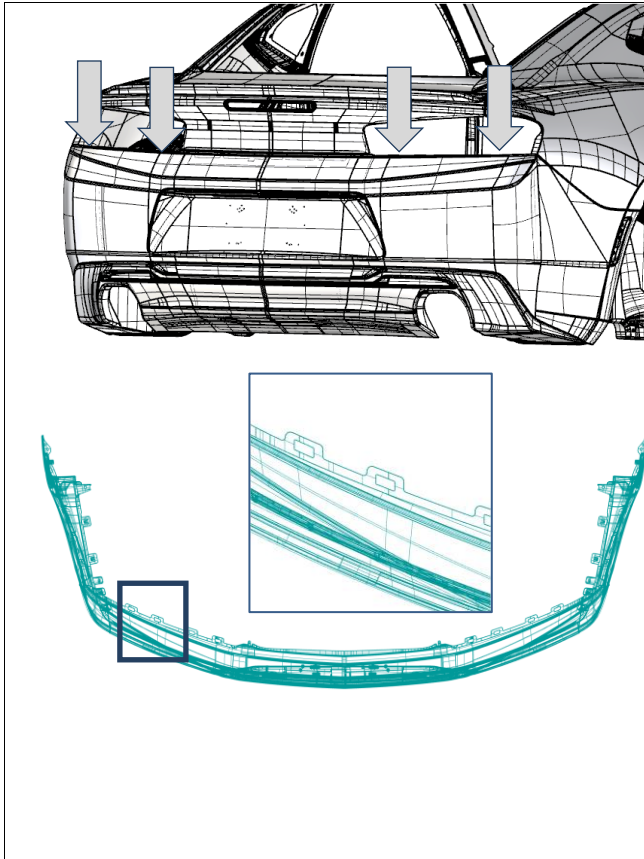

7. Insert a small wedge between the fascia and rear fascia guide.
8. Insert, carefully, a small flat-bladed tool into the opened slot and depress the snaps one at a time. See image for reference.
 - a. Tip: Pull the fascia at the same time to gradually remove the fascia from the rear fascia guide.
9. Disconnect all electrical connectors.
10. Remove rear fascia assembly.

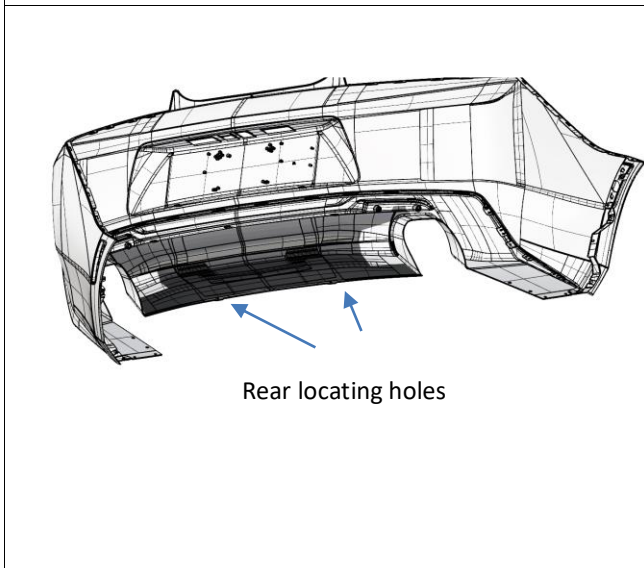

11. Cut the 'ACS Drilling/Trimming template' along the outside edge.
12. Place the ACS Drilling/Trimming template on the *inside* of the Camaro's valence.
 - a. Line up the template using the rear location holes.

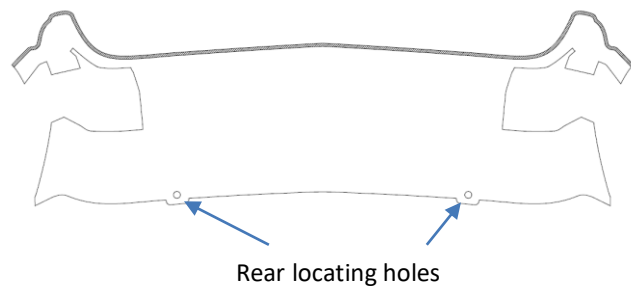

Gen6 Quad Tip Diffuser
48-4-045

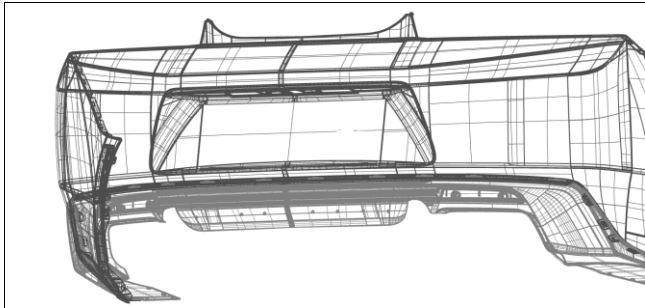

13. Scribe the inside surface of the valence using the template as the guide.
14. Trim the valence using a Dremel tool or a small disk cutter.

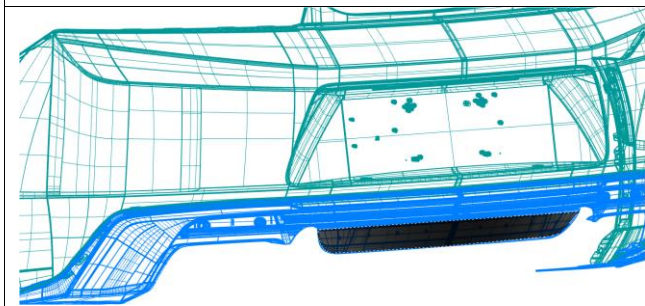

15. Place the 'Drilling Template' on the *outside* of the valence.
16. Drill the (9) pilot 1/8" holes.
17. Remove the 'Drilling Template'
18. Redrill holes from step 16 using a 1/4" bit

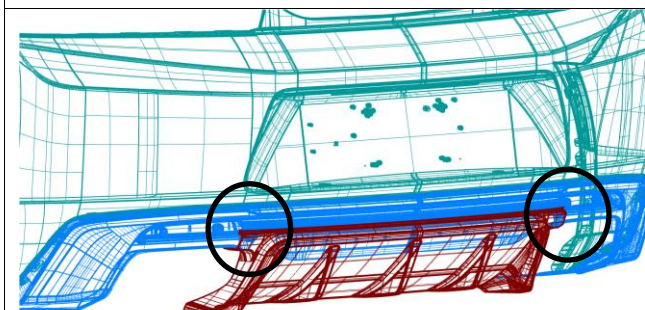

19. Place the ACS Diffuser Panel on the rear valence.
20. From the backside of the panel, install the (9) SEM screws that were drilled in step 16.
21. Two pre-drilled holes are located on either side of the ACS rear diffuser panel (See circled diagram).
 - a. Drill (2) 3/16" holes through the valence on either side using the ACS panel as your guide.
22. Install the two supplied rivets on either side.
23. Reverse steps 10-2 to reinstall the rear fascia assembly of the Camaro.

Gen6 Quad Tip Diffuser
48-4-045



Congratulations! Installation is complete.

We invite you to share images on our Facebook and Instagram Page.

Search: ACS Composite

For questions or comments please email us at: info@acscomposite.com

ADVANCED COMPOSITE SPECIALTIES (ACS) PARTS WARRANTY

All ACS panels are covered by a 90-day warranty, to be free from defects in material and workmanship, from date of retail purchase (proof of purchase required). There are NO OTHER warranties expressed or implied on ACS hoods.

Panels are warranted to the original purchaser. The warranty is not transferable or assignable. A copy of the original dated sales receipt must accompany any hood returned for a warranty claim. During the warranty period, ACS will, at its discretion, repair or replace any panel found to be defective in material and workmanship. All panels must be returned with shipping PREPAID to ACS in Montreal, Quebec. COD shipments will be refused. It is the customer's responsibility to obtain a RMA (Return Material Authorization) number from ACS before returning any hood.

IN THE EVENT OF A POSSIBLE DEFECT IN MATERIAL OR WORKMANSHIP, THE RESPONSIBILITY OF ACS IS STRICTLY LIMITED TO EITHER THE REPAIR OR REPLACEMENT OF THE PANEL. ACS WILL NOT BE RESPONSIBLE FOR A) INCIDENTAL AND CONSEQUENTIAL DAMAGES, PROPERTY DAMAGE, OR PERSONAL INJURY DAMAGES TO THE EXTENT PERMITTED BY LAW; B) ACTUAL OR ALLEGED LABOR, TRANSPORTATION, OR OTHER INCIDENTAL OR CONSEQUENTIAL CHARGES; C) STORAGE OR RENTAL CAR CHARGES.