

# INSTALLATION GUIDE

# AMP RESEARCH Power Step

MADE IN USA

## APPLICATION

## AMP Part #

Chevrolet Silverado1500 / GMC Sierra 1500 - Double Cab *	2014-18	75154-01A-B
Chevrolet Silverado1500 / GMC Sierra 1500- Crew Cab	2014-18	75154-01A-B
Chevrolet Silverado HD / GMC Sierra HD - Double Cab * (excludes diesel engine)	2015-19	75154-01A-B
Chevrolet Silverado HD / GMC Sierra HD- Crew Cab (excludes diesel engine)	2015-19	75154-01A-B

\* Modification required to running board assembly. See Item 1 on page 3.

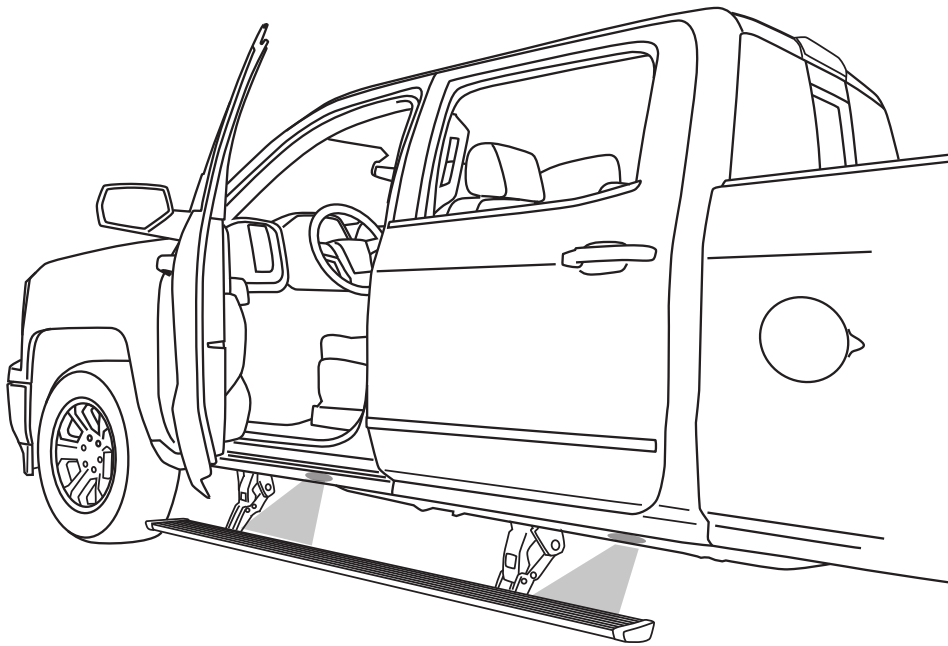

### INSTALLATION TIME

**3-5 Hours**

Professional installation recommended

### SKILL LEVEL



4= Experienced

### TOOLS REQUIRED

- Safety goggles
- Measuring tape
- Flat blade screwdriver
- Power Drill
- 9/32" drill bit
- 13 mm socket
- 10 mm socket
- 7 mm socket
- Ratchet wrench and extension
- 13mm end wrench
- Wire crimpers
- Wire stripper / cutter
- 3/16" hex key wrench (allen wrench)
- 5mm hex key wrench (allen wrench)
- 4mm hex key wrench ( allen wrench )
- Electrical tape
- Weather proof caulking (silicone sealer)
- Silicone spray

### WARRANTY

**5-Year Limited Warranty**

AMP RESEARCH TECH SUPPORT 1-888-983-2204 (Press 2) Monday - Friday, 7:00 AM - 5:00 PM PST

Invented, engineered and manufactured exclusively by AMP Research in the USA. May be covered by one of the following patents: 6,641,158; 6,830,257; 6,834,875; 6,938,909; 7,055,839; 7,380,807; 7,398,985; 7,584,975 ©2012 AMP Research. All rights reserved. Printed in USA.

## INSTALLATION GUIDE

### Attaching motor to Linkage assembly

The motors must be attached to the Linkage assemblies before continuing the installation process.

#### EXPLODED VIEW

- Motor
- Gear Cover
- Socket Cap Screw
- Washer

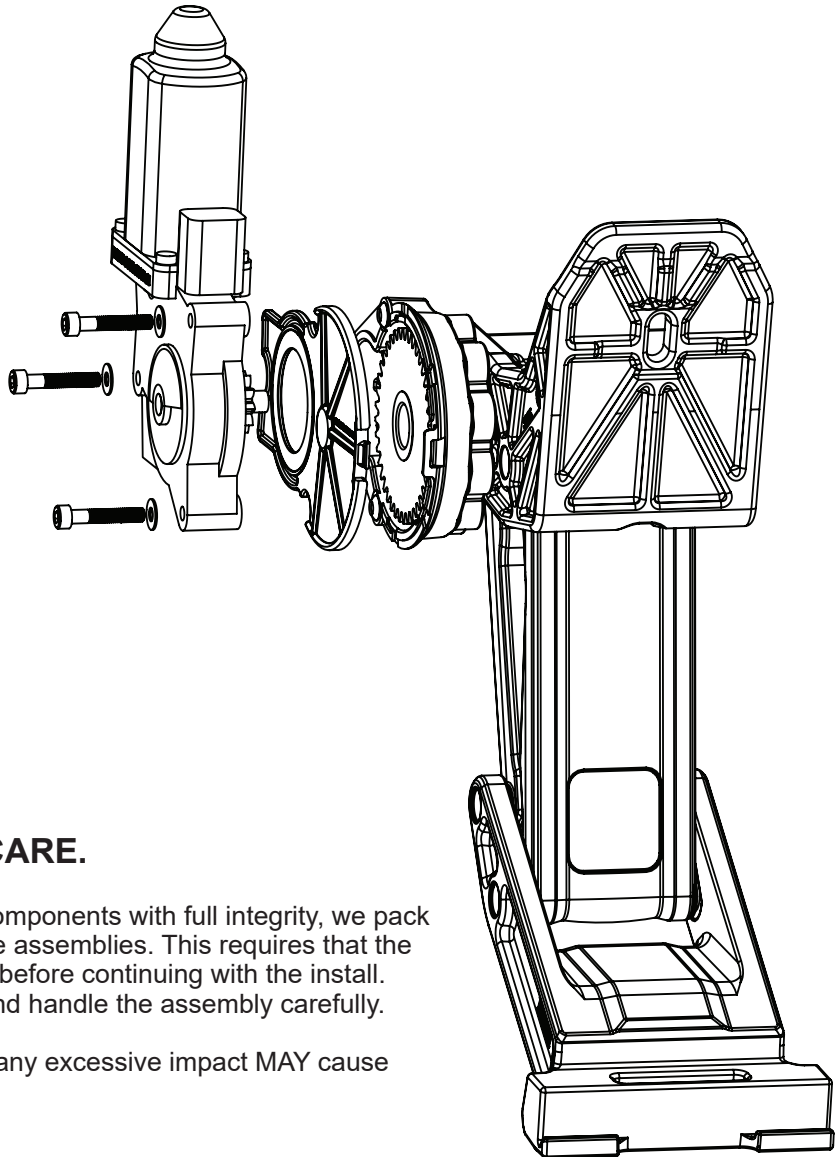

#### CAUTION: HANDLE WITH CARE.

To ensure our customers receive all components with full integrity, we pack the motors separate from their Linkage assemblies. This requires that the installer position and fasten the motor before continuing with the install. Please follow the instructions below and handle the assembly carefully.

CAUTION: Dropping the assembly or any excessive impact MAY cause damage to the motor.

#### Instructions:

1. Position the gear cover in place as shown if not already in place.
2. Seat motor into position on the three mounting bosses. This may require an adjustment of the gear by moving the swing arms.
3. After seating into place, fasten the motor with the three motor mount screws with 4mm Hex Head. Tighten screws to 36 in-lbs (4N-m). **Do not over torque.**

**Note: Some Applications require modification.**

Application	Cut Length
Crew Cab	79" (No Modification Required)
Extended Cab	72" (Trim 7")

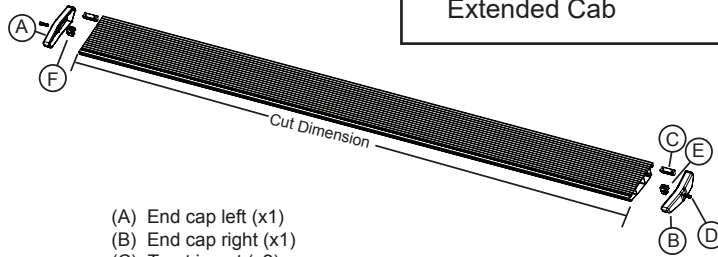

- (A) End cap left (x1)
- (B) End cap right (x1)
- (C) T-nut insert (x2)
- (D) Socket cap screw (x2)
- (E) End cap wedge right (x1)
- (F) End cap wedge left (x1)

1 x2

Running board assembly

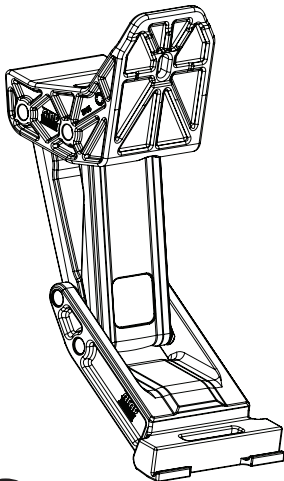

2 x2

Idler Linkage assembly

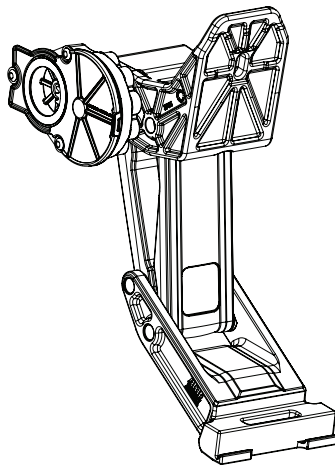

3 x2

Motor Linkage assembly



4

Wire harness

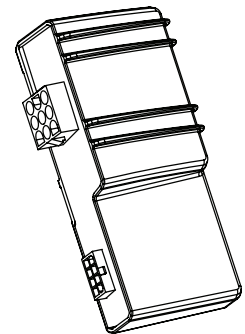

5

Controller STA

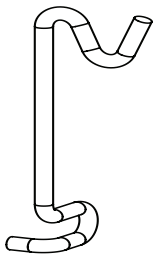

6

Brake Cable Bracket

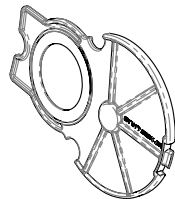

7 x2

Gear Cover

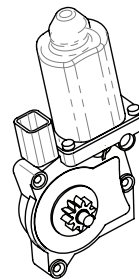

8 x2

Brose Motor

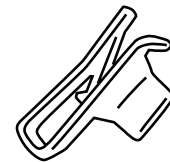

9

U-nut

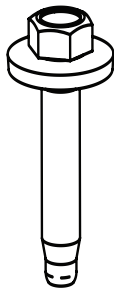

**10** x4  
Hex Bolt with Conical Washer

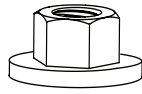

**11** x4  
Nut with Conical Washer

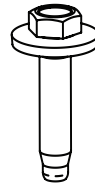

**12** x5  
Hex Bolt with Conical Washer

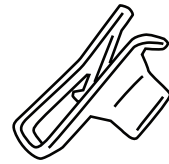

**13** x4  
U-nut

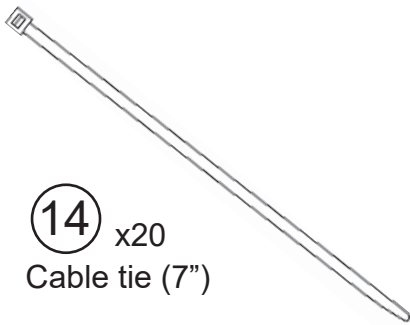

**14** x20  
Cable tie (7")

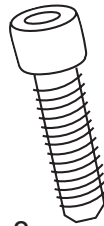

**15** x8  
Socket Cap Screw

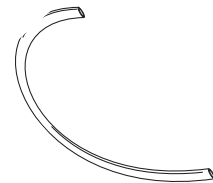

**16**  
Tubing (Installation Tool)

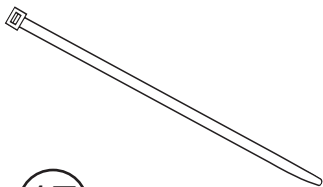

**17** x2  
Cable tie (11")



**18** x4  
Posi-Tap™



**19** x2  
Grommet

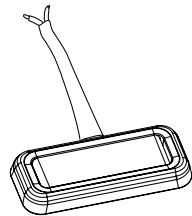

**20** x4  
LED Lamp

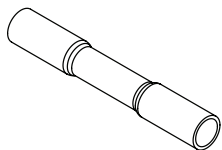

**21** x10  
Butt Connector

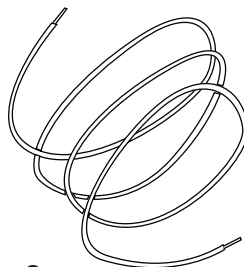

**22** x2  
Connecting Red Wire

**1500 MODELS ONLY!**

Install U Nut (13) into position just forward of brake cable T junction. Use supplied bolt (12) to hold Brake cable rod into position.

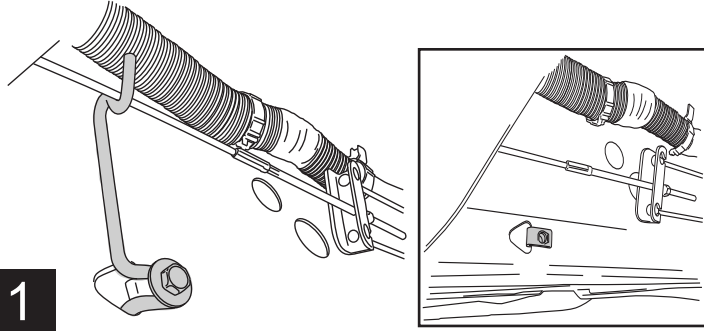

**1**

**Front Idler Linkage:** Thread supplied bolt (10) in about half way into the first sheetmetal tab / hole from front. Set linkage over bolt and Tighten lower bolt (10) to 16ft-lbs (22N m). Finger tighten nut (11) onto bolt (10). Install bolt (12) and torque to 16 ft-lb (22N m). Next torque lower nut (11) to 16 ft-lb (22N m) using wrench to hold lower bolt in place.

Note: Threaded nut may not be present on some vehicles. Bolt will assemble the same as step 3.

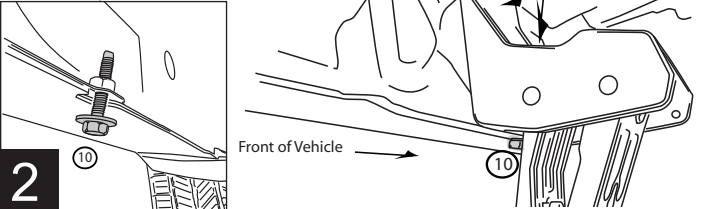

**2**

**Rear Drive Linkage:** Install driver side Motor Linkage in fourth sheetmetal tab / hole from front. Linkage will then clear parking brake cable.

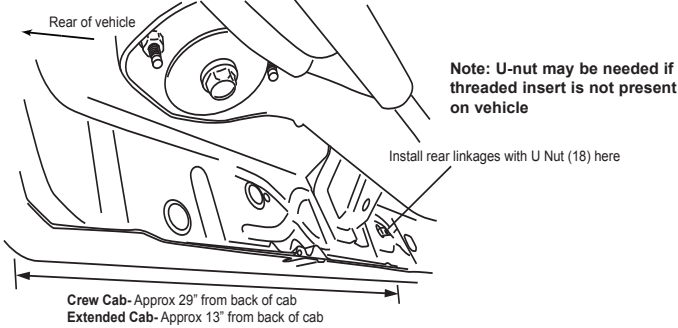

NOTE: U Nut may not be needed on some model trucks.

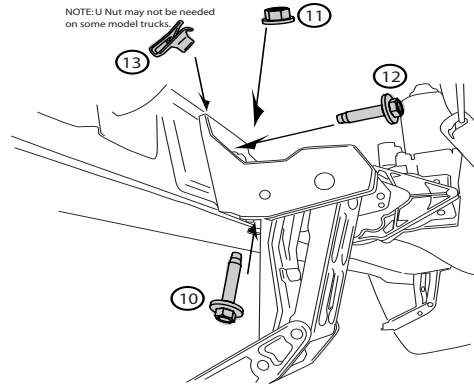

**3** Set linkage into second to last sheetmetal tab / hole from rear. Use supplied bolt (10) and nut (11) to hold in position. Install bolt (12) into upper mounting hole and snug both bolts. Torque upper bolt (12) to 16ft-lbs (22N m) first and then torque lower bolt (10) and nut (11) to 16 ft-lb (22N m). Repeat linkage installation on Passenger side.

Slide mounting T-nut into position, aligning the end of the board with the rear edge of the back door. Mount board and tighten fasteners to 10 ft-lbs. Insure linkages are squared to body prior to torquing fasteners.

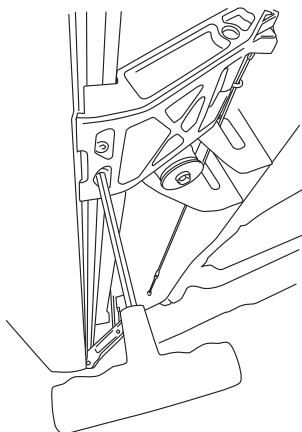

**4**

Using the two 11" cable ties, mount controller to support arm next to battery. Plug in harness (Ensure that locking tabs engage)

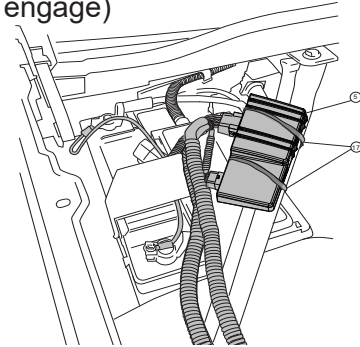

Remove power fuse. Attach power lead (RED wire) to positive pole on the battery. Attach ground lead to negative battery pole.

**5 CAUTION:** Do not ground wrench when engaged with nut.

**5**

Route long end of wire harness above engine and down through drivers side wheel well. Zip tie harness to cowl clips on fire wall. Route short end down passengers side.

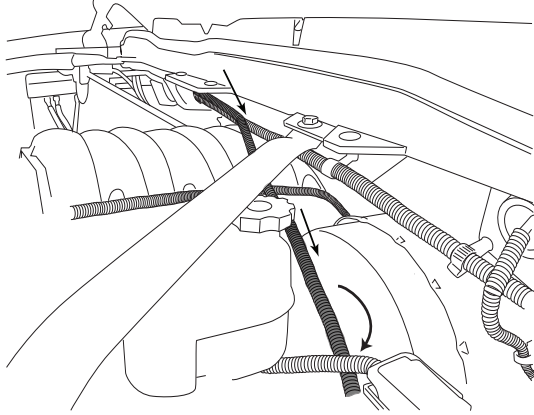

6

Pull up front door sill plate covers as shown.

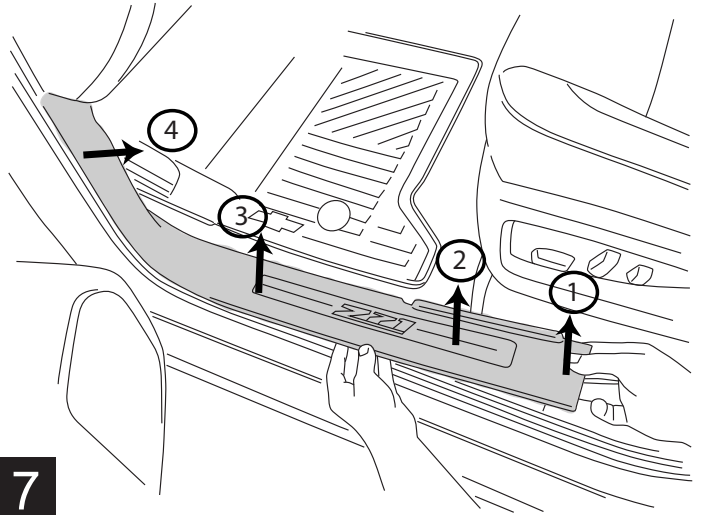

7

Pull up the carpet and drill 9/32" hole in metal and insert supplied rubber grommet

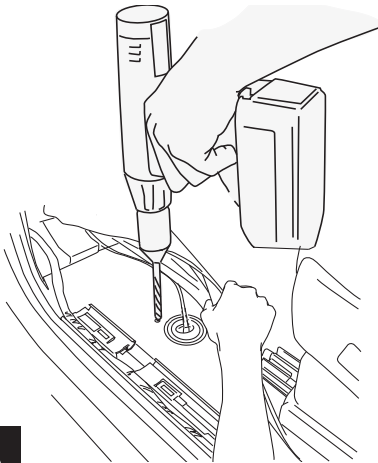

8

Route wire harness along the frame and back towards rear linkage. Secure with zip ties. Push both wires through rubber grommets. Connect harness to motor. Secure harness with tie wraps.

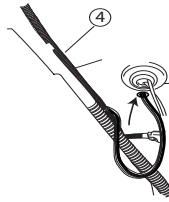

NOTE: Seal holes with silicone glue and cover with tape so carpet does not stick to glue.

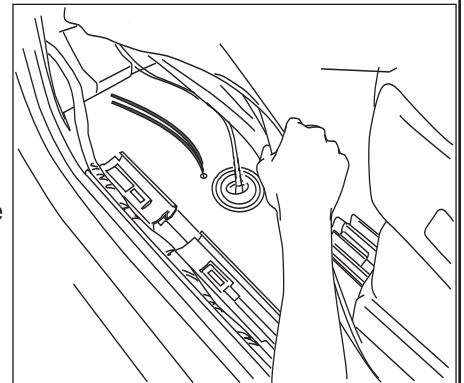

9

## FRONT DOOR WIRING: Steps 13-30 are for front doors

**FRONT DOOR WIRING:** Pop cover plate off. Work your way across the bottom of cover. Once bottom is popped loose pull down and out.

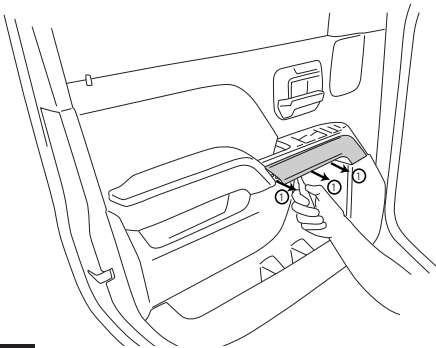

10

Remove Front door Cover plates behind door handle and in bottom of grab handle to access mounting

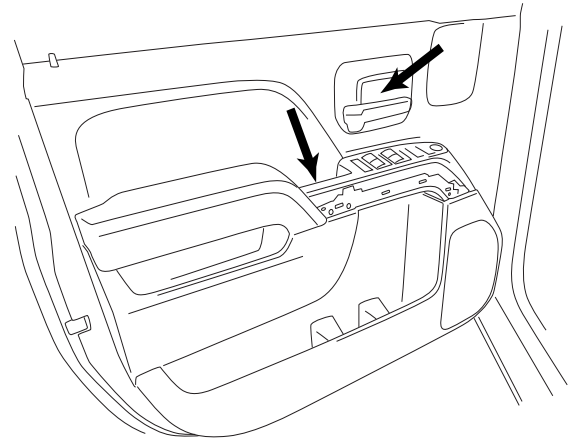

11

**AMP RESEARCH POWERSTEP™ – CHEVROLET / GMC**

Using a 7mm socket remove the 6 screws that secure the door panel in place.

Pry all panel fasteners loose. Start at door hinge side and work your way around the bottom and towards latch side of door.

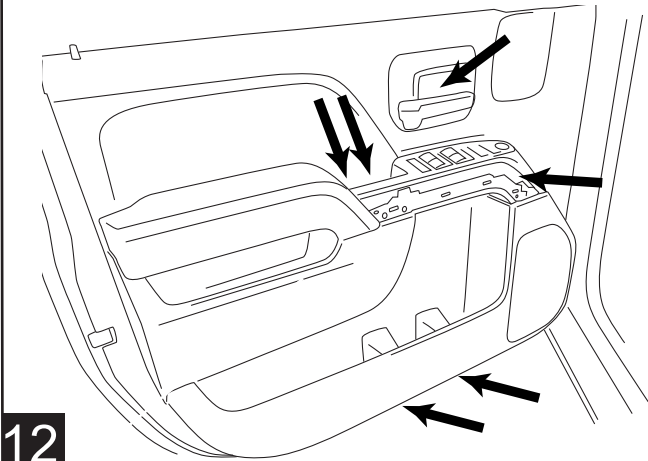

**12**

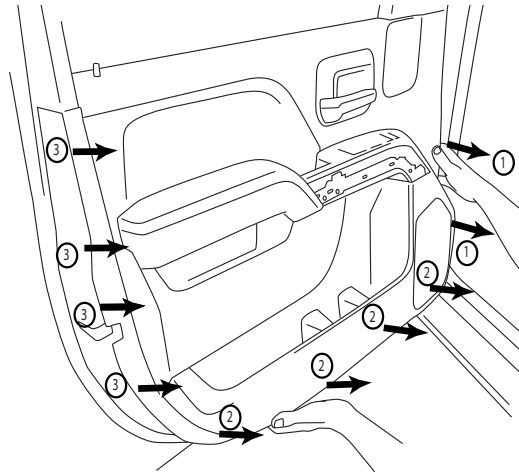

**13**

Once panel pins are out lift up on panel. Lift panel up and off of door.

Remove door latch cable from door panel.

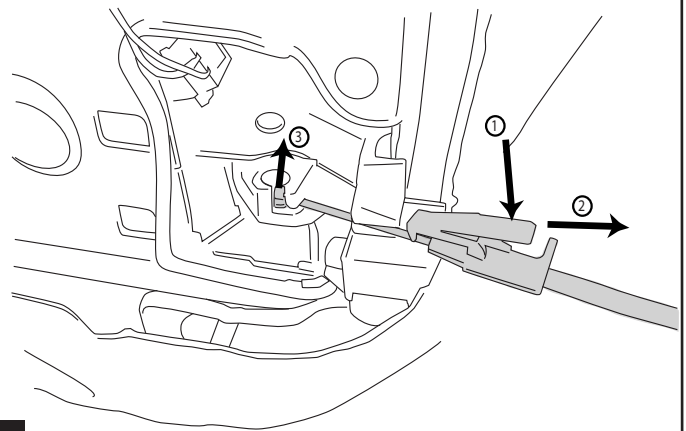
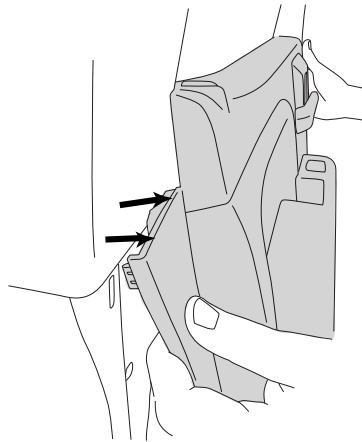

**14**

**15**

Remove plug from door panel.

Remove accordion seal at door jamb and use supplied red wire and route wire into kickpanel.

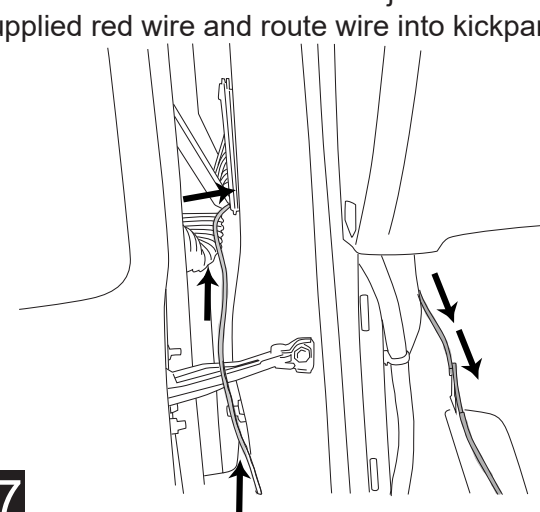
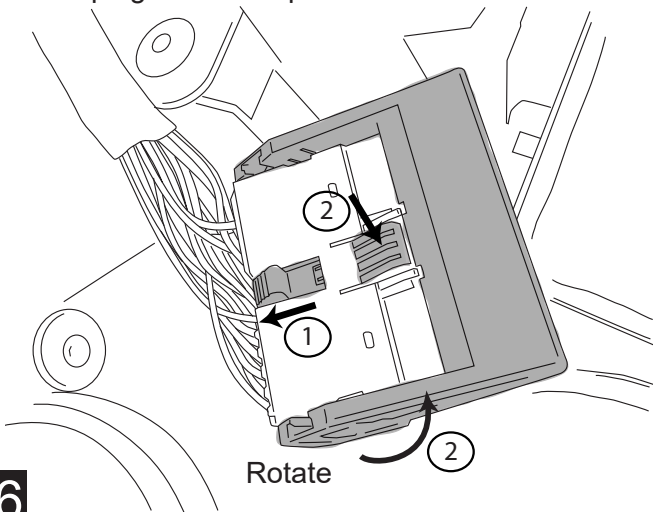

**16**

**17**

AMP RESEARCH POWERSTEP™ – CHEVROLET / GMC

Tape red wire to (grey with black wire on driver side and tan with white stripe on passenger side). Pull trigger wire out and remove red wire. Next run trigger wire thru rubber accordion. Save red wire for rear doors.

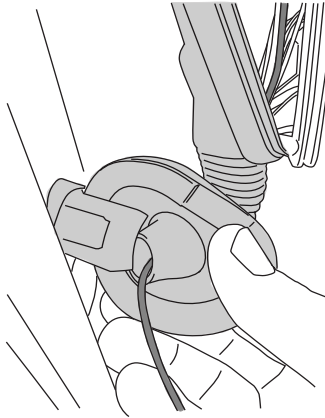

18

Route trigger wire into the door. Poke hole through rubber grommet and push wire through. Pull back door weather guard and run wire across door panel to door switch plug.

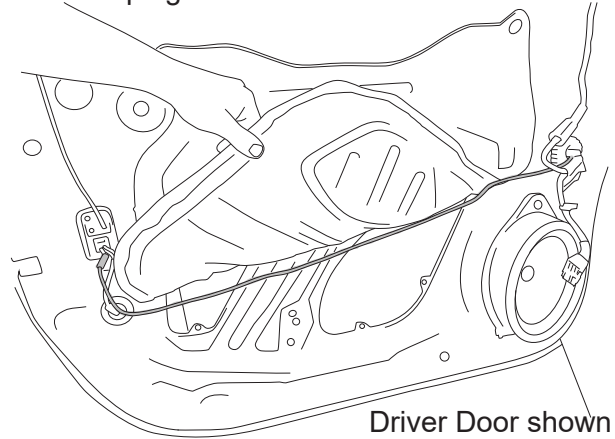

Driver Door shown

19

Posi-Tap™ instructions

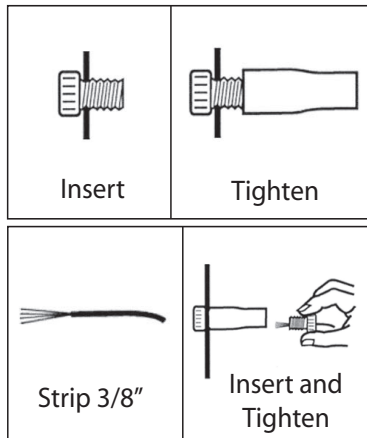

Using supplied Posi-Tap connector connect trigger wire on harness (Driver Side: Grey/Black Stripe & Passenger Side: Tan/White Stripe) to Solid dark grey wire on door switch plug. Passenger side shares the same color wire. **Note: Wire is located in the upper outer pin of plug. (Left on Driver, Right on Passenger Side)**

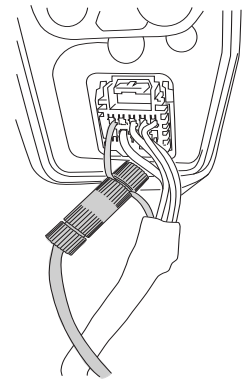

21

Remove seal on door panel by removing metal clips that attach it to panel with a flat screwdriver.

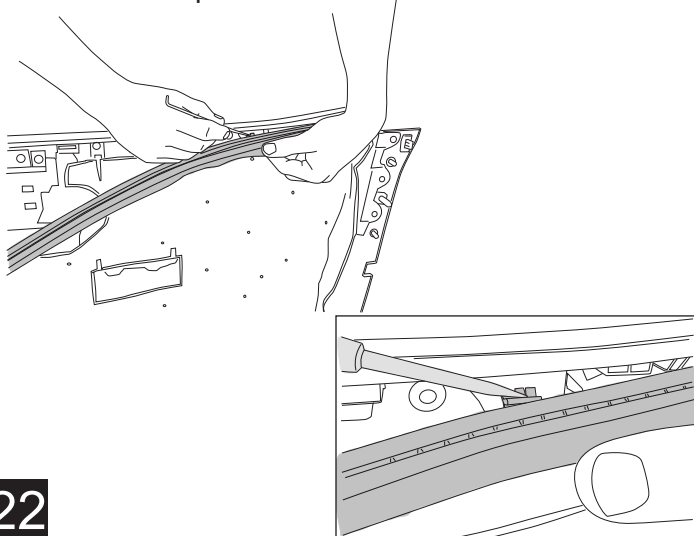

Attach clips to grooves in door.

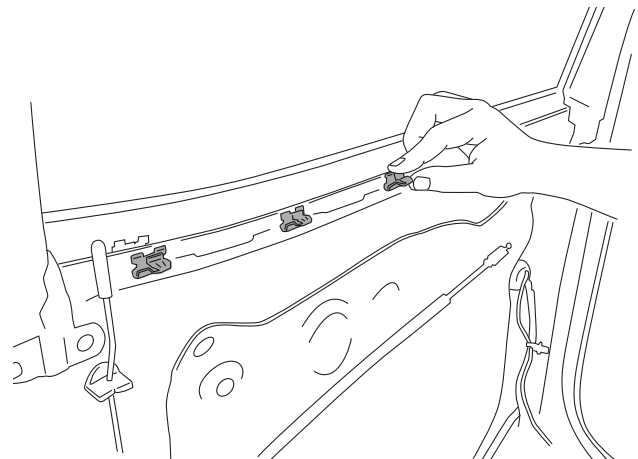

22

23



Re-attach window seal. Ensure seal is pushed against edge.

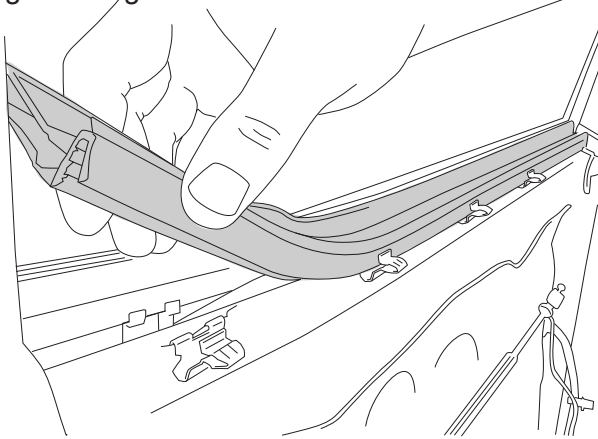

24

Replace plug and door latch cable. Reassemble door panel and replace screws removed from step 14.

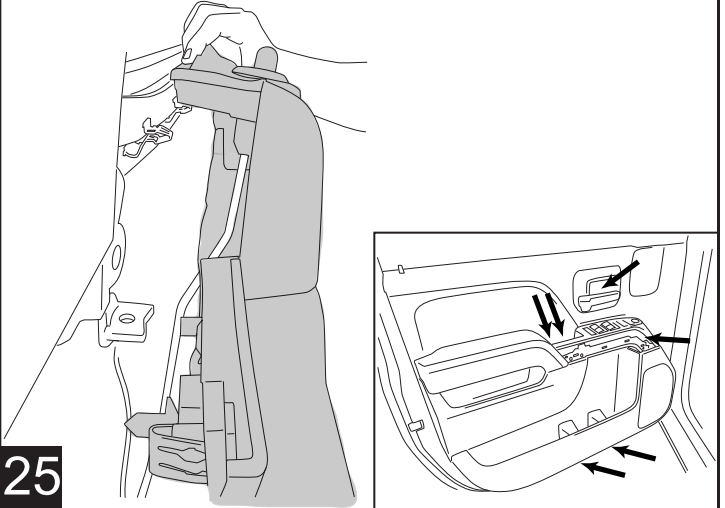

25

Replace cover plates.

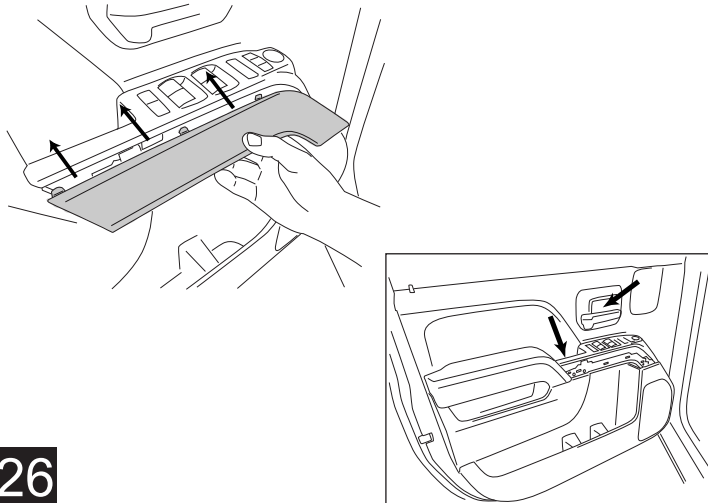

26

Reassemble accordion boot by removing retainer ring from body. Slide boot over ring and reattach to vehicle.

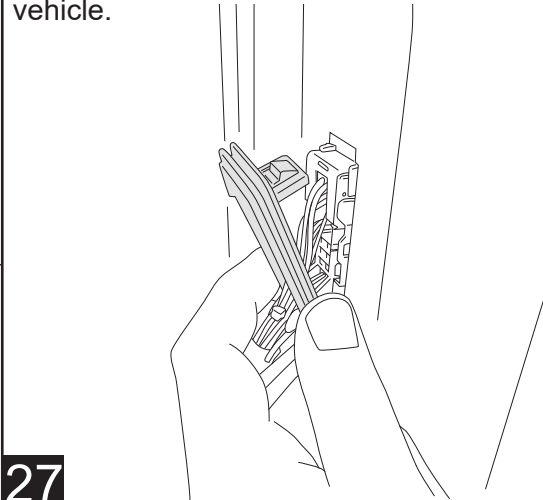

27

## REAR DOOR WIRING: Steps 28-38 are for rear doors

Pull up rear sill plate cover as shown.

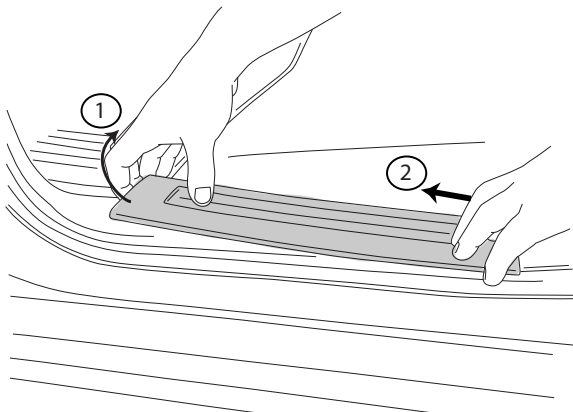

28

Pull back b pillar interior panel to gain access. Pull back accordion seal.

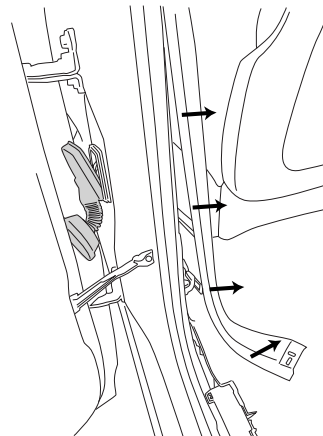

29

AMP RESEARCH POWERSTEP™ – CHEVROLET / GMC

Use supplied red wire and feed through accordion and into door panel.



30

Feed wire to front sill area. Run wire between door seal and black wire casing. Place wire under loom and connect red wire to powerstep trigger wire (Light blue and black stripe on driver side and Green with a black stripe on passenger side) with supplied butt connector. Once crimped use heat gun to shrink tube.

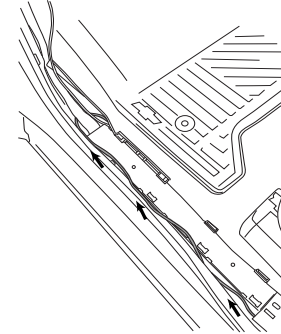

31

Remove Rear door Cover plates behind door handle and in bottom of grab handle to access mounting screws.

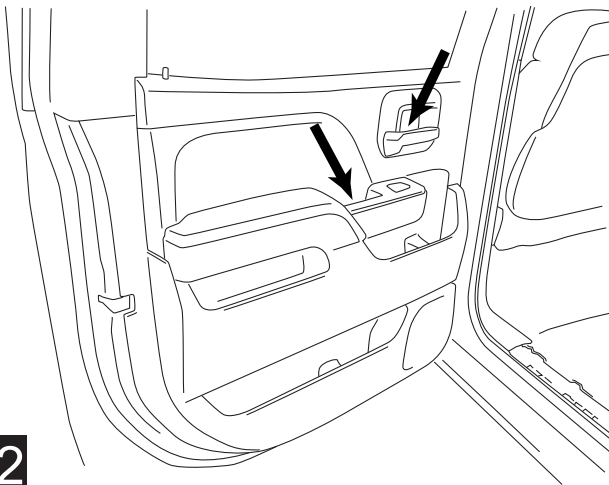

32

Using a 7mm socket remove the 4 screws that secure the rear door panel in place.

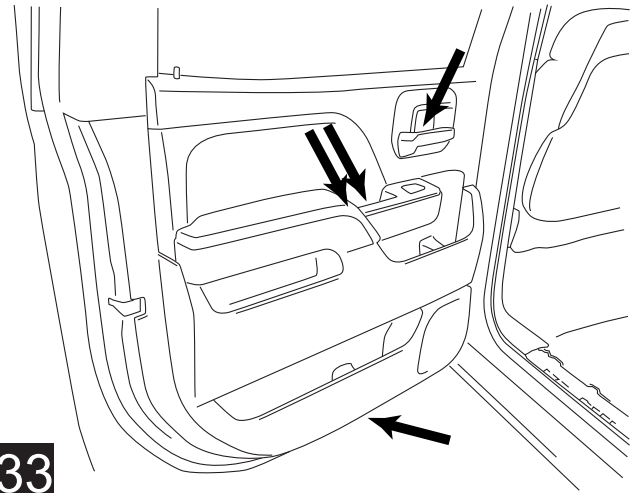

33

Pry all panel fasteners loose. Start at door hinge side and work your way around the bottom and towards latch side of door.

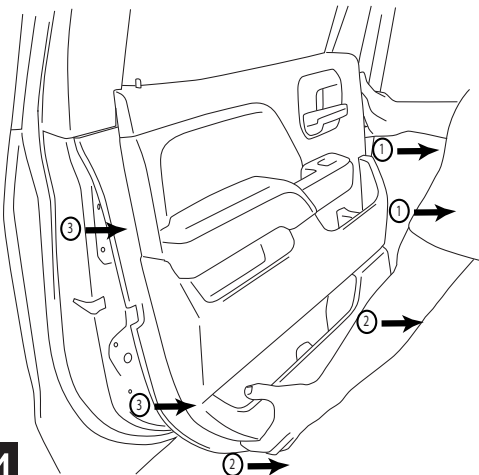

34

Once panel pins are out lift up on panel. Lift panel up and off of door.

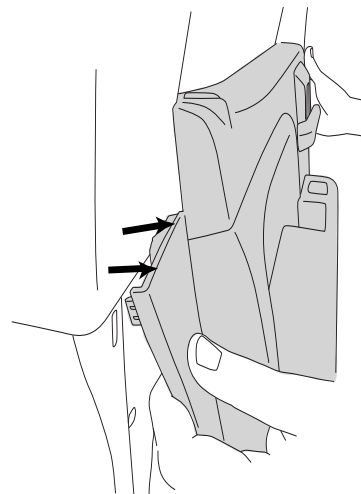

35

Remove door latch cable from door panel.

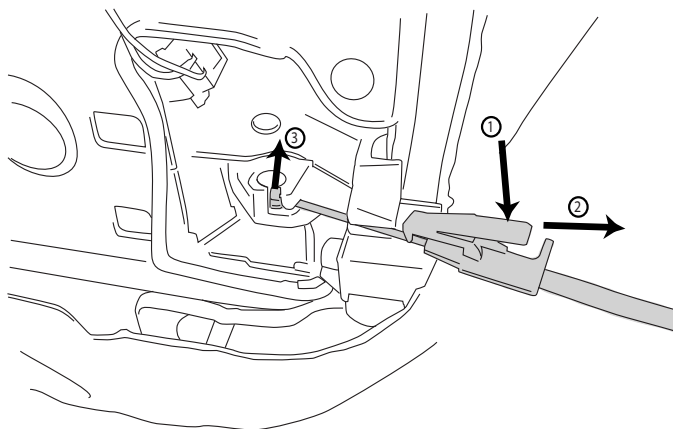

36

Route trigger wire into the door. Poke hole through rubber grommet and push wire through. Pull back door weather guard and run wire across rear door panel to door switch plug.

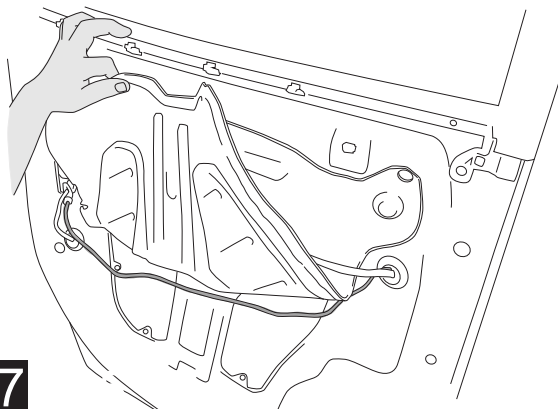

37

Using supplied Posi-Tap connector connect trigger wire to dark grey with white stripe wire on door switch plug. Passenger side shares the same color wire. **Note: Wire is located in the upper outer pin of plug. (Left on Driver, Right on Passenger Side)**

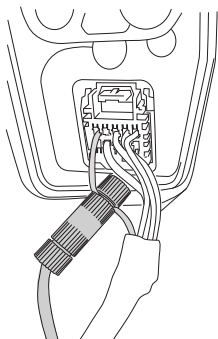

38 Repeat steps 32-37 for door panel reassembly.

On each side of the vehicle measure from the front edge of door line on the pinch weld to the specified lengths below. Measure at 23" for front LED Light and 63" for rear LED Light.

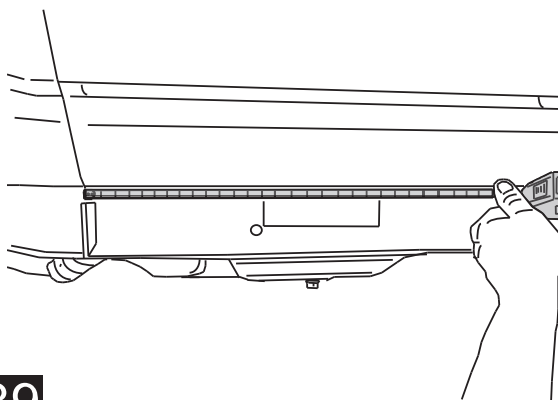

39

Affix lamp to rocker panel surface. Make sure the lamp is affixed to a clean, flat surface. There is a step down midway across the surface. Affix lamp just outside of step down.

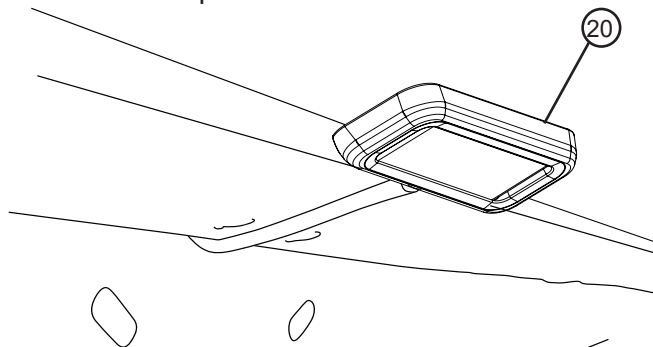

40

Using supplied butt connectors, connect the lamp wires. Red to Red, Black to Black. Once Crimped use heat gun to shrink tube. Close and wrap conduit with electrical tape. Secure all loose wires with cable ties. Pull lamp wires upward to avoid any wire snagging.

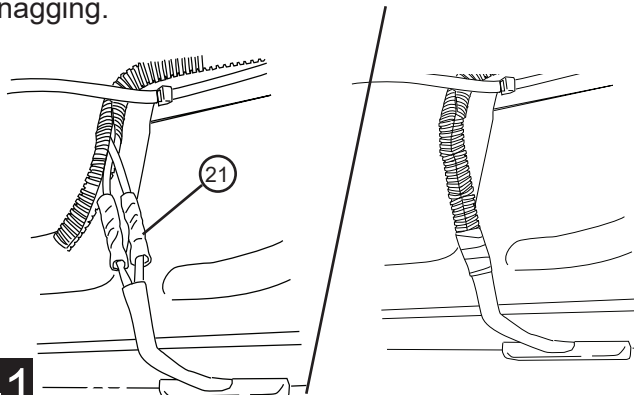

41

Reinstall fuse. Check that all doors activate the Power Step and the LED Lights work when doors open and close. Reinstall any remaining trim panels.

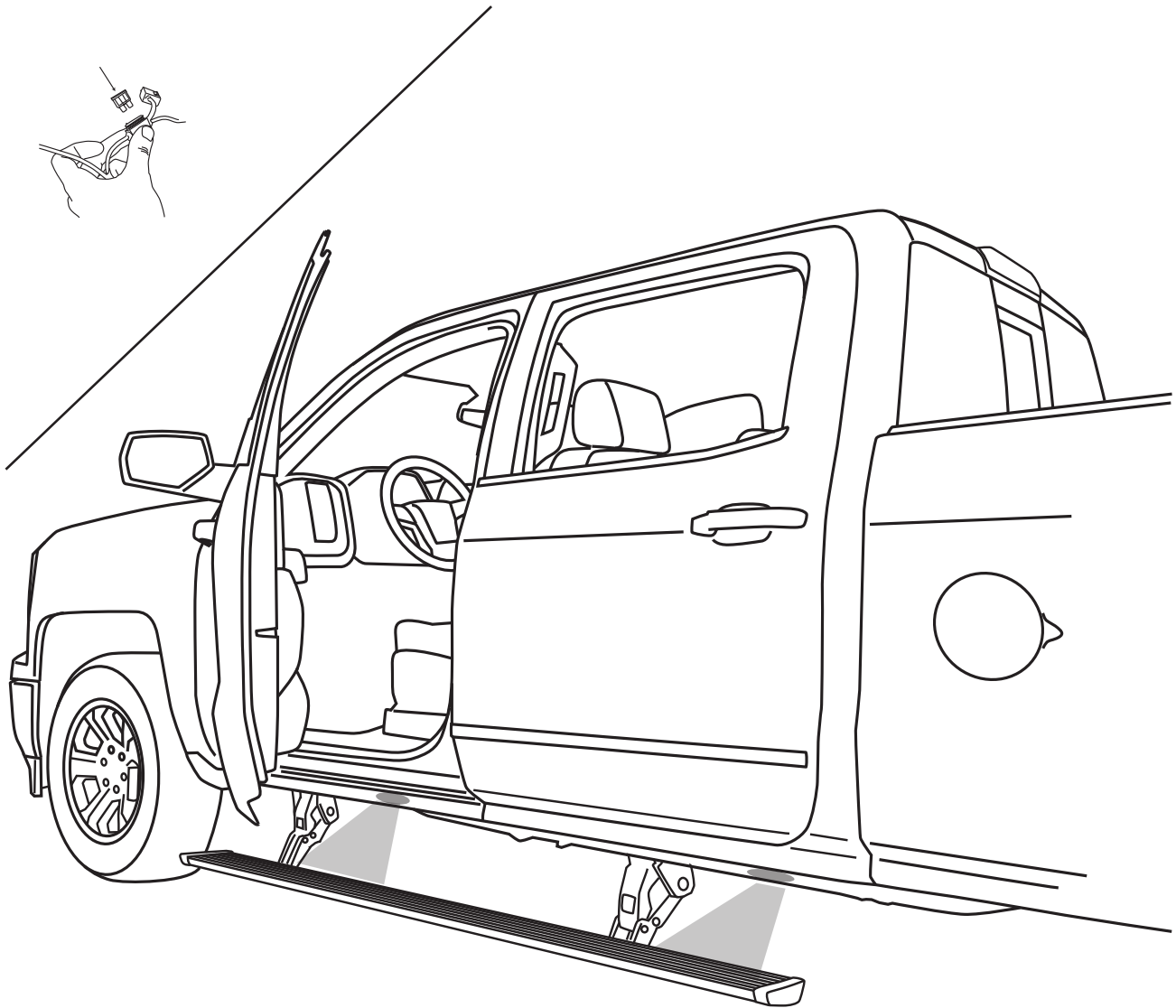

#### FINAL SYSTEM CHECK

Check that all doors activate the PowerStep and the LED lights work when doors open and close.

**NORMAL OPERATION:** When the doors open, PowerStep automatically deploys from under the vehicle. When the doors are closed, PowerStep will automatically return to the stowed/retracted position. **Note that there is a 2-second delay before the PowerStep returns to the stowed/retracted position.**

**CORRECT OPERATION OF LIGHTS:** All four lamps will illuminate upon opening any door of vehicle. Lamps will stay on until restowing of both Power Steps or until 5 minutes has expired with the doors open. When the lights timeout after 5 minutes, they can be reilluminated by closing and opening any door of vehicle.



# PowerStep™

AMERICAN DESIGNED, ENGINEERED AND MANUFACTURED.

**Thank you for your recent AMP Research Purchase.**

**REGISTER YOUR PRODUCT TODAY FOR  
FASTER SERVICE & PRODUCT UPDATES**

Please visit:

**[www.amp-research.com/productregistration](http://www.amp-research.com/productregistration)**

or scan the QR Code



**Product Registration Benefits:**

- Ensure we have your purchase receipt and product info in our system which is required for warranty
- Faster and easier access to customer service and tech support in the unlikely event you need warranty or product support
- Registration helps us keep you up to date on product information and offers

To view other Amp Research products that may be offered for your vehicle.

**Please visit: [www.amp-research.com](http://www.amp-research.com)**

Rev 01.05.21

# AMP RESEARCH PowerStep™

Congratulations on your purchase of the genuine AMP Research PowerStep!  
Here's what you should know...

**POWER-DEPLOYABLE RUNNING BOARDS OPERATION:** AMP Research PowerStep running boards automatically move when the doors are opened to assist entering and exiting the vehicle.



**Automatic power deploy:**

The running boards will extend down and out when the doors are opened.

**Automatic power stow:**

The running boards will return to the stowed position when the doors are closed. There will be a 2-second delay before the running boards move to the stowed position.

**Automatic stop:**

If an object is in the way of the moving running board, the running board will automatically stop. To reset, clear any obstruction, then simply open and close the door to resume normal operation.



**Manually set in the deployed (OUT) position for access to the roof:**

The running boards can be manually set in the deployed position by firmly holding the step down with your foot while at the same time closing the door. To resume normal operation, open and close the door.



**Maintenance:** In adverse conditions, debris such as mud, dirt, and salt may become trapped in the running board mechanism, possibly leading to unwanted noise. If this occurs, manually set the running boards to the deployed position and flush the front and rear hinge arms with a high-pressure car wash wand. Avoid spraying the motors directly. After washing, apply silicone spray lubricant to the hinge pivot pins. Do not apply silicone, wax or protectants like Armor All® to the running board stepping surface.

**Caution!** Keep hands away when the running board is in motion.

## 5-YEAR LIMITED WARRANTY

AMP RESEARCH warrants this product to be free from defects in material and workmanship for FIVE (5) YEARS FROM DATE OF PURCHASE, provided there has been normal use and proper maintenance. This warranty applies to the original purchaser only. All remedies under this warranty are limited to the repair, replacement of the product itself, or the repair or replacement of any component part thereof, found by the factory to be defective within the time period specified. The decision to repair or replace is wholly within the discretion of the manufacturer.

This warranty specifically excludes labor. If you have a warranty claim, first you must call our factory at the number below for instructions. You must retain proof of purchase and submit a copy with any items returned for warranty work. Upon completion of warranty work, if any, we will return the repaired or replaced item or items to you freight prepaid. Damage to our products caused by accidents, fire, vandalism, negligence, misinstallation, misuse, Acts of God, or by defective parts not manufactured by us, is not covered under this warranty.

ANY IMPLIED WARRANTIES OF MERCHANTABILITY AND/OR FITNESS FOR A PARTICULAR PURPOSE CREATED HEREBY ARE LIMITED IN DURATION TO THE SAME DURATION AND SCOPE AS THE EXPRESS WRITTEN WARRANTY. OUR COMPANY SHALL NOT BE LIABLE FOR ANY INCIDENTAL OR CONSEQUENTIAL DAMAGE.

Some states do not allow limitations on how long an implied warranty lasts, or the exclusion or limitation of incidental or consequential damages, so the above limitations or exclusions may not apply to you. This warranty gives you specific legal rights, and you may also have other rights that vary from state to state.

**FOR WARRANTY ISSUES WITH THIS PRODUCT PLEASE CALL AMP RESEARCH CUSTOMER SERVICE 1-888-983-2204**

## WARNING

Be sure to read and precisely follow the provided instructions when installing this product. Failure to do so could place the vehicle occupants in a potentially dangerous situation. After installing or reinstalling, re-check to insure that the product is properly installed.



The material that your product is made from can be recycled.  
Please also consider recycling the packaging that your product came in.

