



C8 Corvette Wickerbill Spoiler Installation

Part Numbers:

CV-C8R190001-PASB (Satin Black) & CV-C8R190001-PACM (Carbon Flash Metallic)

Parts List

Description	Qty.
Spoiler	1
Lexan Flap	1
M6 Billet Washer	6
M6 Screw	6
M6 Nylok Nut	6
M6 Flat Washer	6
M6 Threaded Stud	6
Installation Instructions	1
Template Sheet	1

Required Tools

- Power Drill
- 4 mm (1/8") Drill Bit
- 7 mm (5/16") Drill Bit
- 9 mm (3/8") Drill Bit
- Ratchet
- Extension
- Socket (10mm)
- 4mm Allen Wrench
- 50% Isopropyl Alcohol (IPA)
- Masking Tape
- Loctite®
- Hair Dryer (if vehicle has production spoiler installed)
- Monofilament line (fishing line) (if vehicle has production spoiler installed)

Please verify that all parts are present, including the supplied part.

Caution: If any part of this installation seems beyond your level of installation experience, please seek the help of a certified professional.

Before beginning installation, park the vehicle on a level surface, apply emergency brake and chock the wheels.

Installation Procedure

Locate Drill Locations if vehicle is not equipped with Z51 Spoiler

1. Cut both templates out of template sheet.

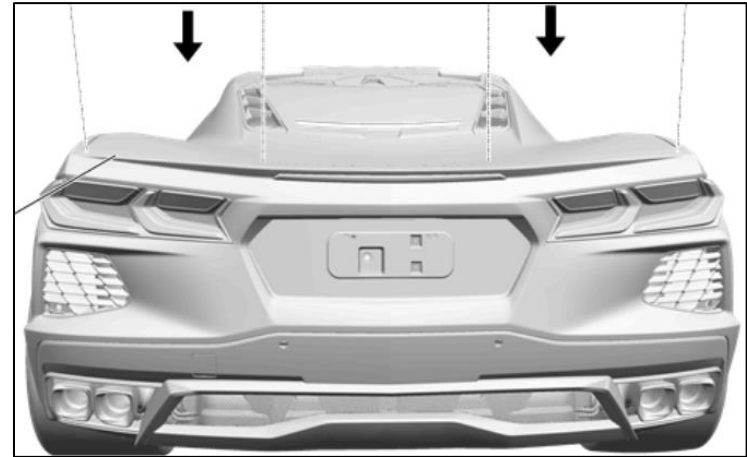

2. Position templates on rear fascia. Follow instructions on the template for layout procedure.

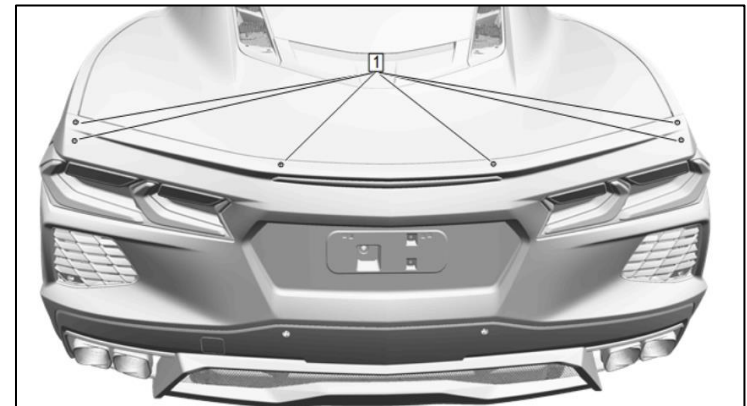

3. Using a punch, mark the 3 hole locations (1) as indicated on templates. Flip templates upside down and repeat for the other side of the vehicle.

Remove Rear Bumper Fascia

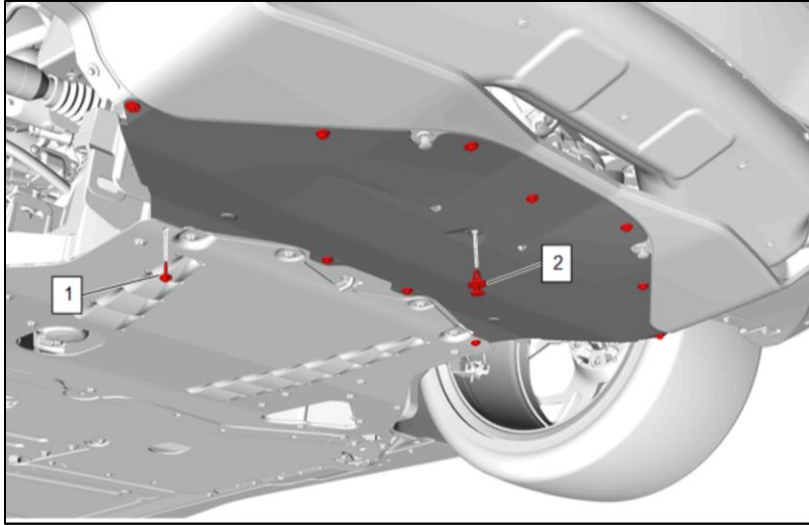

1. Remove the underbody rear air deflector by removing 11 bolts and 1 push clip.

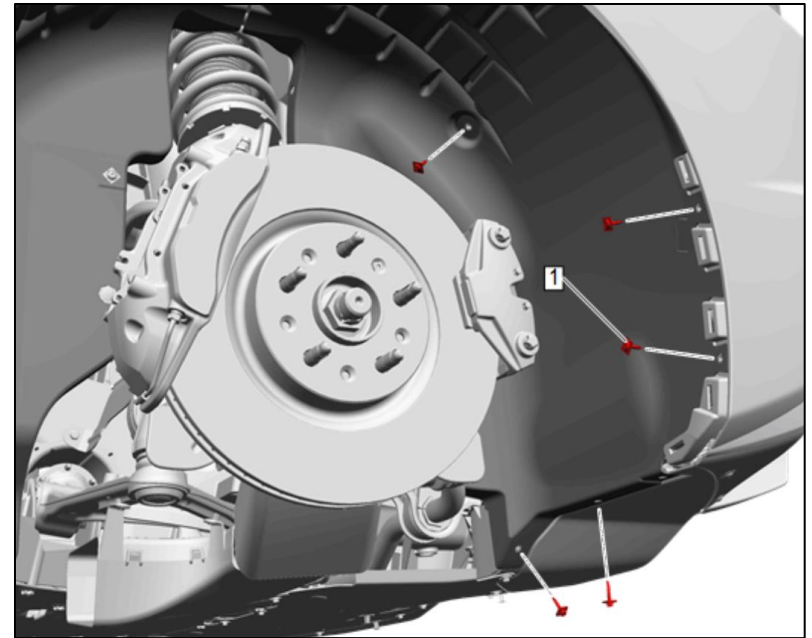

3. Remove 5 inner fender liner bolts on each side.

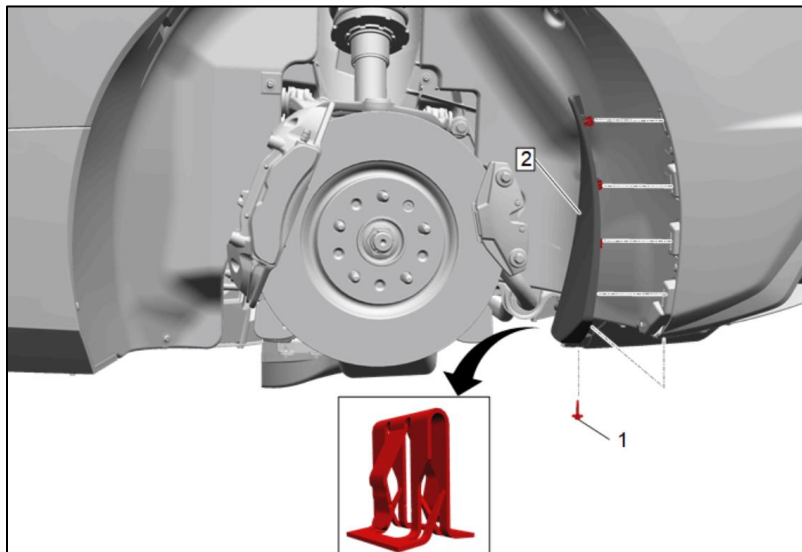

2. Remove the rear wheel moldings on each side.

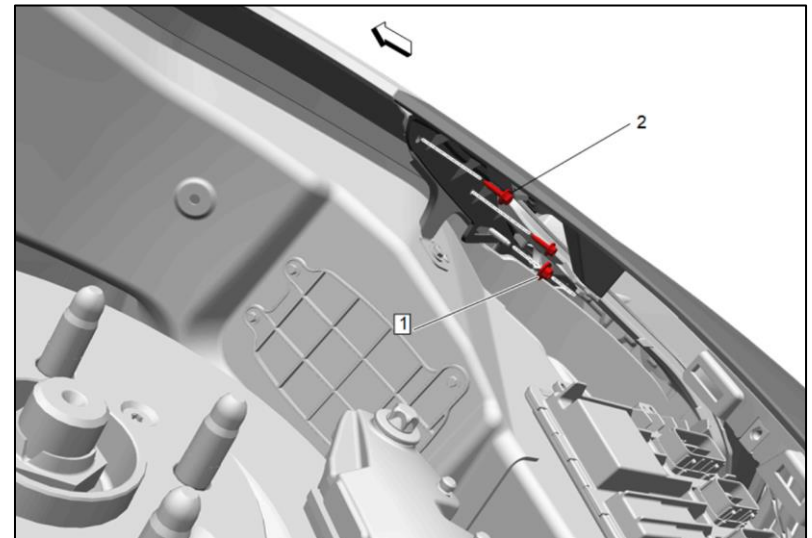

4. Remove 2 rear fascia bolts (2) and 1 rear fascia nut (1) from each side.

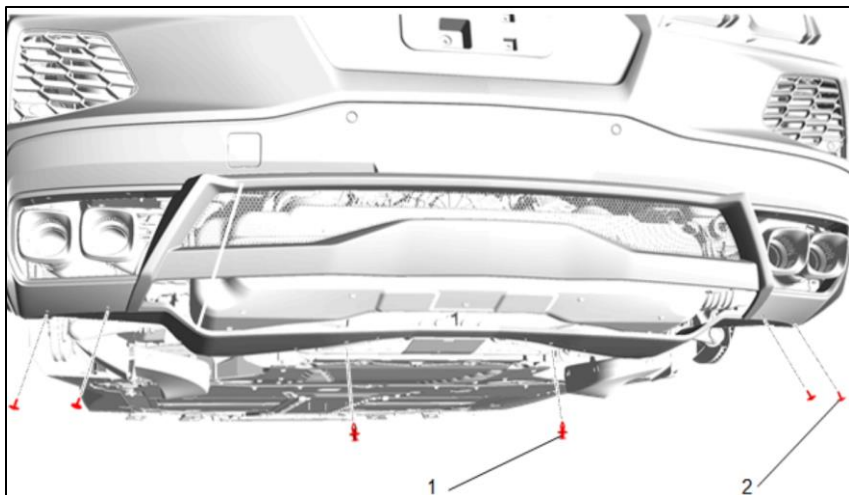

5. Remove 4 rear fascia bolts (2) and 2 push clips (1).

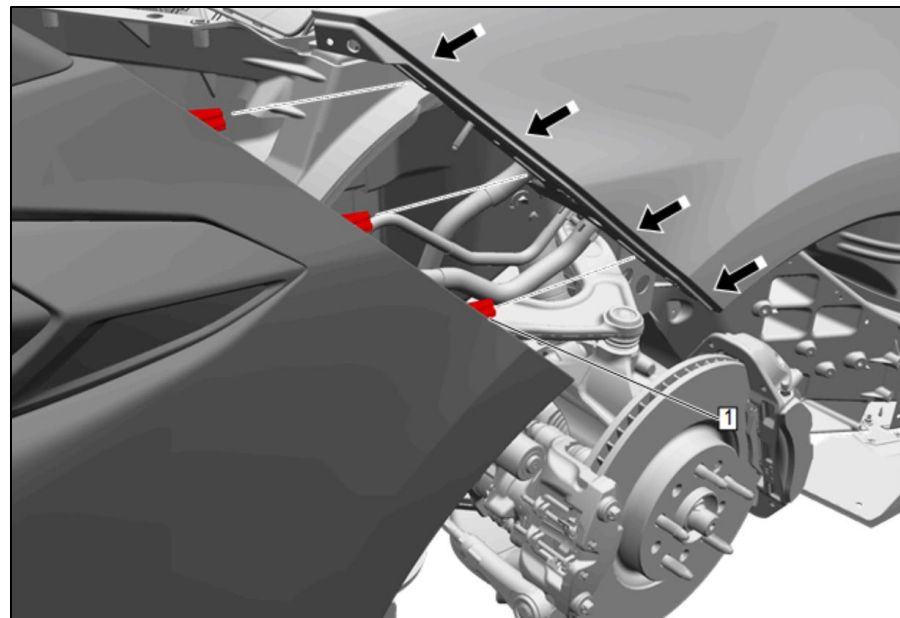

7. Apply two layers of masking tape to the painted surface of the left and right quarter panel to prevent paint damage to the quarter panel.

8. Release the 3 rear bumper fascia tabs (1) on each side.

9. Remove rear bumper fascia and place on a clean suitable surface to prevent damage.

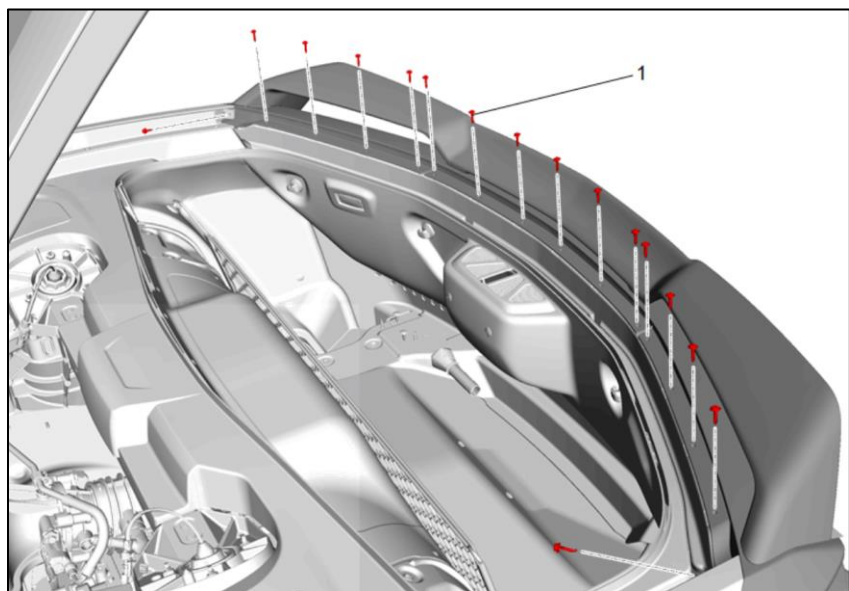

6. Remove 16 rear bumper fascia bolts.

Remove Tail Lights from Rear Bumper Fascia

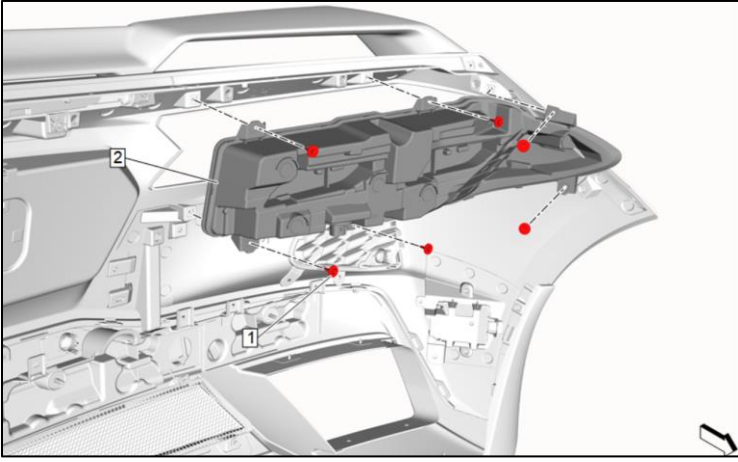

1. Remove 6 tail light bolts (1) and disconnect electrical connector on each side.
2. Remove both tail lights and place on a clean suitable surface.

Remove High Mount Stop Lamp from Rear Bumper Fascia

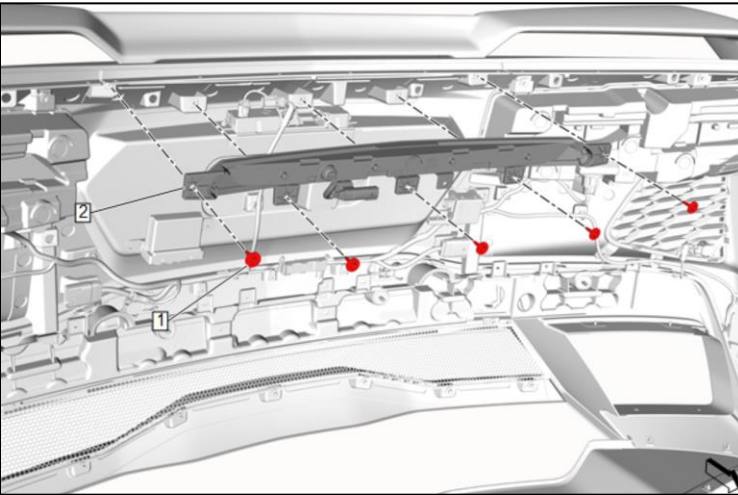

1. Remove 5 stop lamp bolts (1) and disconnect electrical connector.
2. Remove high mount stop lamp and place on a clean suitable surface.

Remove Existing Rear Spoiler, if Equipped

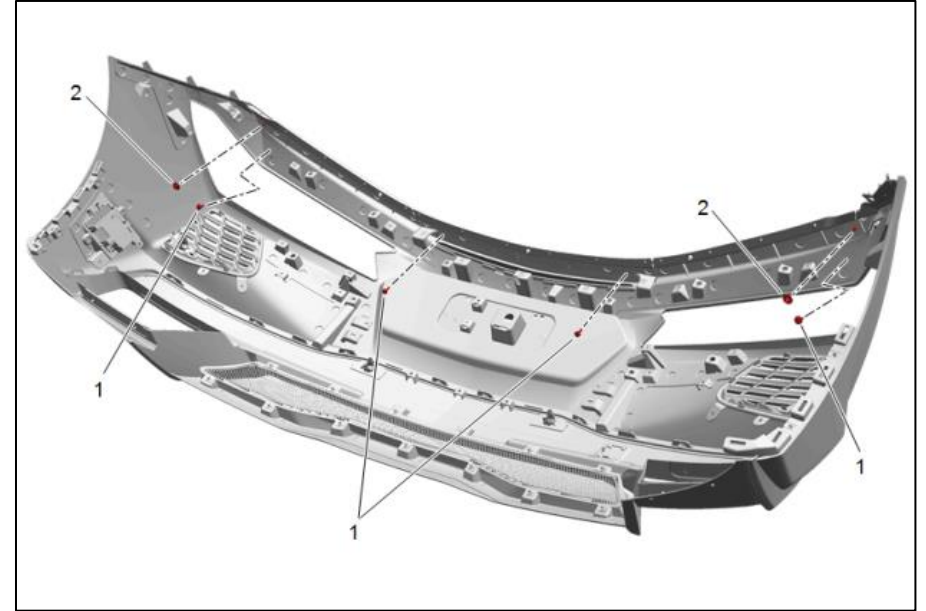

Note: If vehicle is equipped with rear spoiler, proceed with the next five steps. If vehicle is not equipped with rear spoiler, proceed to [Drilling Spoiler Mounting Holes](#) section.

1. Remove the four bolts (1) and two nuts (2) securing the rear spoiler to the rear bumper fascia.

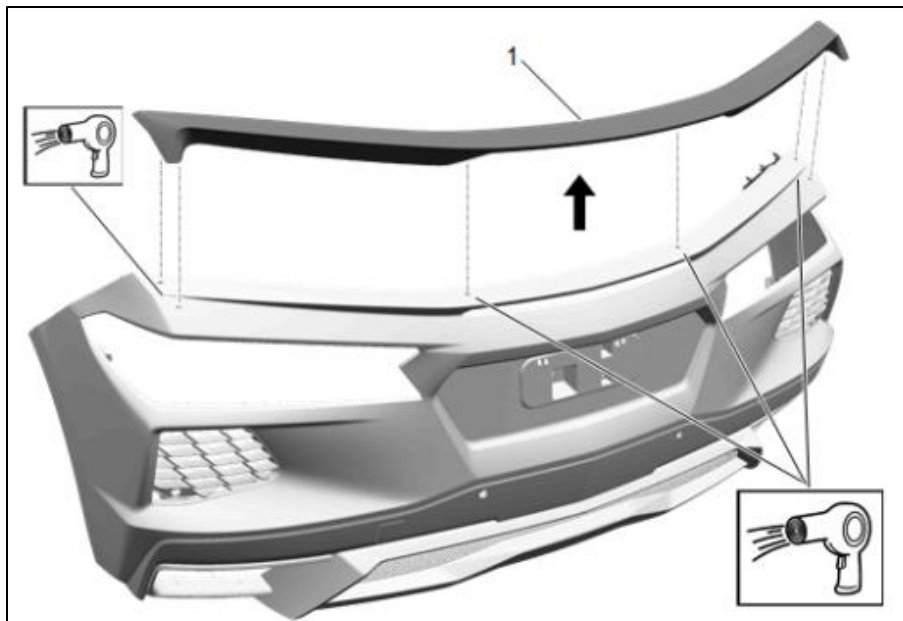

Caution: Applying excessive heat to the rear fascia/spoiler may damage the paint and surrounding panel surfaces during removal. Heat temperature SHOULD NOT exceed 79°C (175°F).

2. Heat adhesive at base of spoiler mounting with low heat (Personal Hair dryer) until adhesive can be sliced easily with a piece of monofilament line (fishing line).
 - 2.1. **IMPORTANT! DO NOT USE A HEAT GUN.** (Heat gun temperatures will soften material and damage paint).
 - 2.2. **IMPORTANT! DO NOT PRY THE SPOILER** off of the fascia with a plastic, metal, or wood trim removal tools in an attempt to loosen the adhesive tape.
3. Use a piece monofilament line (fishing line) and make several knots spaced about 1 inch apart.
4. Use the knotted monofilament line (fishing line) to saw through the tape and remove the spoiler.
5. Clean tape and adhesive from previous spoiler mounting area. Once complete, proceed to **Spoiler Installation** section.

Drilling Spoiler Mounting Holes

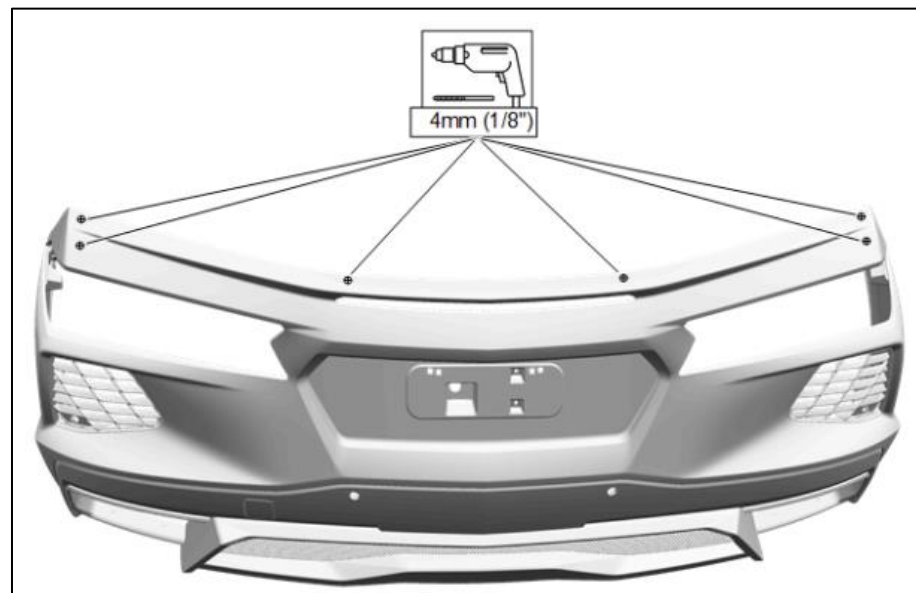

Caution: Always check scale, size, and position of all templates before drilling. Failing to do so may cause damage to the vehicle, misalignment of components, or the inability to install the accessory.

1. Using a 4mm (1/8") drill bit, drill pilot holes in the punched locations on the rear bumper fascia.
2. Drill through holes with 7mm (5/16") then 9mm (3/8") drill bits.

Spoiler Installation

1. Apply Loctite® and hand thread 6 M6 threaded studs (1) into spoiler (2) in locations shown.
2. Clean spoiler mounting surface on rear bumper fascia with 50% isopropyl alcohol (IPA).
3. Peel back tape liner (roughly 1") and use masking tape to secure it to the top surface of the spoiler.

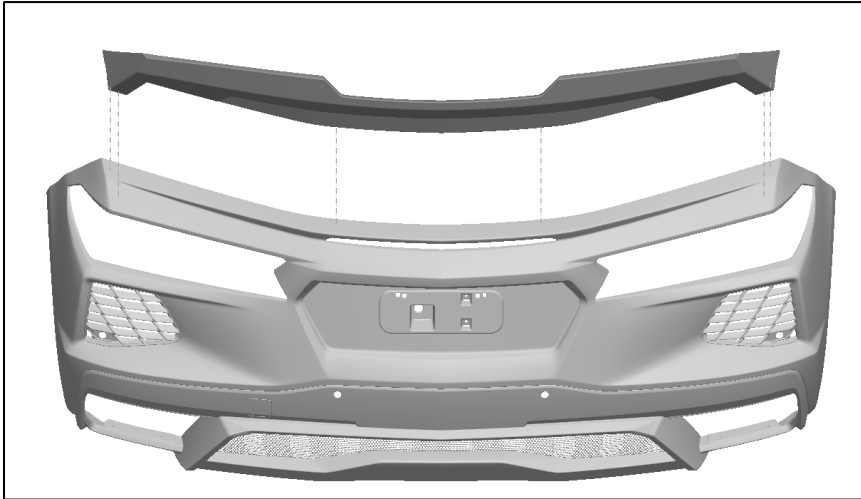

4. Install spoiler on rear bumper fascia using threaded rods to locate properly.
5. Install 6 flat washers and nylok nuts onto the threaded rods from the underside of the rear fascia until snug. **Do not fully tighten.**
6. Peel release film from the tape.
7. Apply even pressure onto the tape surface and hold for tape to fully adhere.
8. Tighten all 6 Nylok nuts. **Be sure not to overtighten.**

Lexan Flap Installation

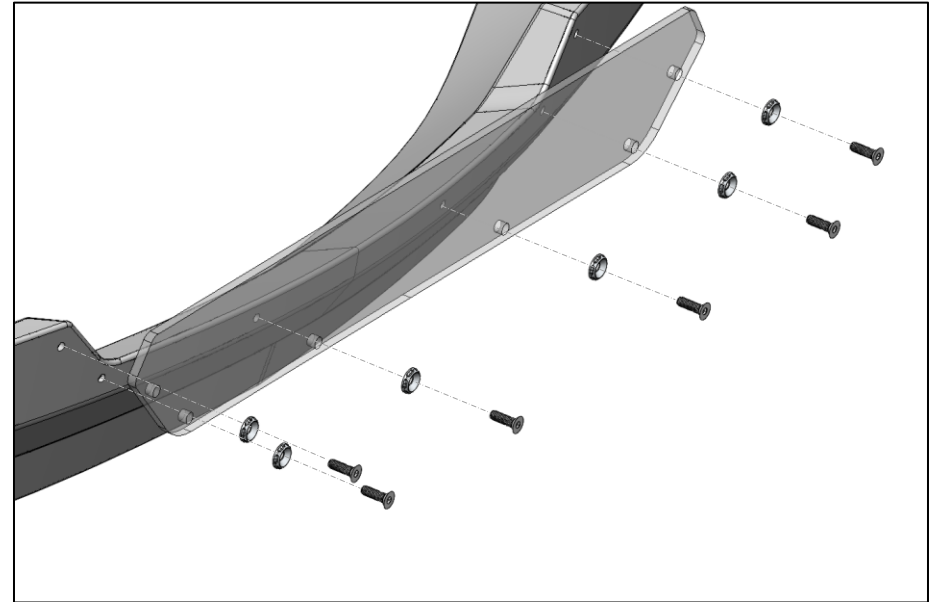

1. Install Lexan flap with 6 billet washers and 6 flat head screws as shown using a 4mm Allen wrench. **Be sure not to overtighten.**

Reinstall All Components in the Opposite Order They Were Removed

Check Function of High Mount Stop Lamp and Tail Lights

Holley® Performance Products, Inc.
1801 Russellville Road
Bowling Green, KY 42101

Technical Support: 1-866-464-6553
Phone: 1-270-781-9741
www.holley.com

© 2021 Holley Performance Products, Inc. All rights reserved. Tous Droits Réservés.

199R12382
Date: 3-7-22