

# S5085

2019-UP GMC/CHEV 1500, 5.3L, CAT  
BACK DUAL, FACTORY REPLACEMENT

# MBRP

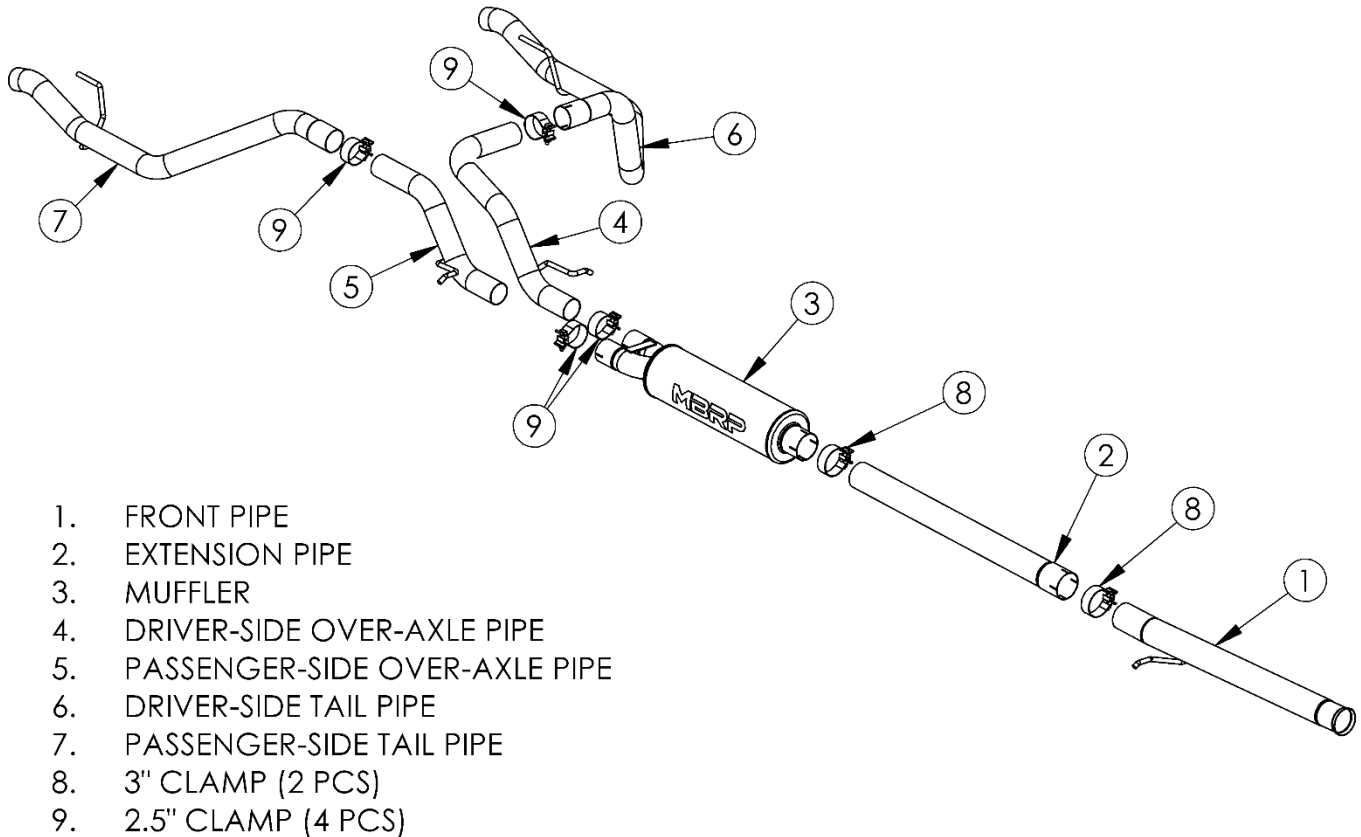

## PLEASE READ BEFORE STARTING INSTALLATION

While MBRP Inc. has made every effort to ensure that all components of this system are of superior quality and properly packaged, it is the installer's responsibility to ensure the following before removal of the factory exhaust:

- that ALL components shown above are present.
- that ALL mating components fit together.
- that there are no damaged components.
- that the system you have purchased is appropriate for your vehicle year, model and configuration.
- that the system will not interfere with any modifications previously installed or planned.
- that you have read and understand these instructions.

If you have any questions or are uncertain about any aspect of the installation of this system to your vehicle please contact your dealer before commencing installation.

# MBRP

## Removal of Stock System



**Figure 1**

1. Apply penetrating lubricant liberally to all exhaust fasteners, hangers and rubber insulators. Lower the spare tire and remove the heat shield.  
**Refer to Figure 1.**



**Figure 2**

2. Remove the two nuts securing the factory driver-side tail pipe and remove the driver-side tailpipe.  
**Refer to Figure 2.**

3. Remove the clamp after the catalytic converter and save the clamp for the installation.  
**Refer to Figure 3.**

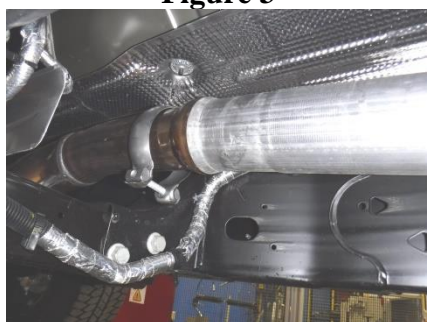

**Figure 3**

4. Remove the hangers from the rubber insulators and remove the exhaust from the vehicle. The rear suspension will need to be relaxed to allow the factory exhaust to be removed without cutting it.

## Installation of MBRP Inc. Performance Exhaust

1. Using the factory clamp removed in Step 3, loosely attach the **Front Pipe** onto the catalytic converter and into the rubber insulator.  
**Refer to Figure 4.**



**Figure 4**

2. Determine the length of the **Extension Pipe** (if required) and cut to length.  
**Refer to Figure 5 (below).**

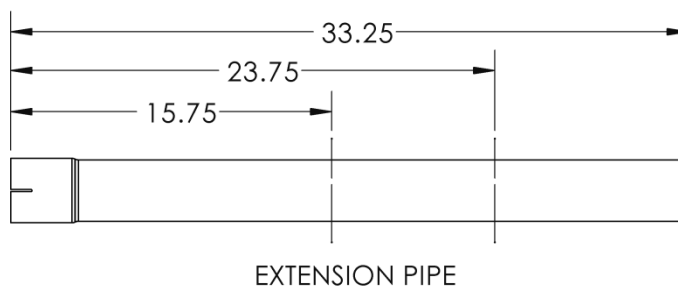

WHEELBASE	EXTENSION PIPE LENGTH
126.4 RC 6'6" BOX	NOT USED
139.5 RC 8' BOX	15.75"
147.4 EC 6'6" BOX / CC 5'8" BOX	23.75"
156.9 CC 6'6" BOX	33.25" (NO CUT)

**Figure 5.**

3. Using a **3" Clamp**, loosely install the **Extension Pipe**.  
**Refer to Figure 6.**



**Figure 6**

4. Using a **3" Clamp**, loosely install the **Muffler** onto the **Extension Pipe**.

# MBRP



**Figure 7**



**Figure 8**



**Figure 9**



**Figure 10**

5. Using a **2.5" Clamp**, loosely install the **Passenger-Side Over-Axle Pipe** into the **Muffler** and into the factory insulator.  
**Refer to Figure 7.**

6. Using a **2.5" Clamp**, loosely install the **Driver-Side Over-Axle Pipe** into the **Muffler** and into the factory insulator.  
**Refer to Figure 8.**

7. Place the **Driver-Side Tail Pipe** into the factory exhaust bezel and factory rubber isolator. Using a **2.5" Clamp**, loosely install the **Driver-Side Tail Pipe** onto the **Driver-Side Over-Axle Pipe**. Orient the **2.5" Clamp** with the bolt on top, nut facing forward; so it will not interfere with the heat shield once re-installed.  
**Refer to Figure 9.**

8. Place the **Passenger-Side Tail Pipe** into the factory exhaust bezel and factory rubber isolator. Loosely install the **Passenger-Side Tail Pipe** onto the **Passenger-Side Over-Axle Pipe** using a **2.5" Clamp**. You may need to remove the factory rubber insulator to clear the pipe joint.  
**Refer to Figure 10.**

9. Re-install the heat shield and raise the spare tire into position.

10. Tighten all hardware and clamps, starting at the front and working rearward to secure the system. Ensure the **Front Pipe Hanger** is level where it passes through the rubber insulator. Check along the full length of the exhaust system to ensure there is adequate clearance for fuel lines, brake lines, frame, bodywork, suspension and any wiring, etc. If there is any interference detected, relocate or adjust to provide adequate clearance.

**Congratulations!** You are ready to begin experiencing the improved power, sound and driving experience of your *MBRP Inc.* Performance Exhaust.

We know you will enjoy your purchase!