

INSTALLATION GUIDE: AWE C7 CORVETTE TRACK OR TOURING EXHAUST

THIS PRODUCT IS INTENDED FOR THE FOLLOWING VEHICLES*:

YEAR	MAKE	MODEL	SUBMODEL	ENGINE
2013-2019	Chevrolet	Corvette	Stingray	6.2L V8
2017-2019	Chevrolet	Corvette	Grand Sport	6.2L V8
2015-2019	Chevrolet	Corvette	Z06	6.2L V8 Supercharged
2019	Chevrolet	Corvette	ZR1	6.2L V8 Supercharged

THIS GUIDE IS INTENDED FOR THE FOLLOWING PART NUMBERS:

3020-42073	AWE Track Edition Axle-back Exhaust for C7 Corvette - Chrome Silver Tips
3020-43081	AWE Track Edition Axle-back Exhaust for C7 Corvette - Diamond Black Tips
3015-42133	AWE Touring Edition Axle-back Exhaust for C7 Corvette - Chrome Silver Tips
3015-43143	AWE Touring Edition Axle-back Exhaust for C7 Corvette - Diamond Black Tips

Welcome to the AWE family, and congratulations on your purchase of the **AWE Track Edition or Touring Edition Exhaust** system for the C7 Corvette.

Exquisite build quality and craftsmanship, coupled with industry leading performance, distinguish this exhaust system from all others.

*For up to the minute fitment information, be sure to visit the AWE website. As always, AWE Performance Specialists are standing by for any questions, [right here](#).

PARTS LIST



INSPECT ALL PARTS PRIOR TO DISASSEMBLY OF VEHICLE; CONFIRM NO PARTS ARE DAMAGED OR MISSING, PLEASE CONTACT THE PLACE OF PURCHASE IMMEDIATELY IF ANY ISSUES.

Axle-Back Exhaust

QTY	Description	Part Number
1	C7 Corvette DS axle tube	B85
1	C7 Corvette PS axle tube	B86
2	3.00in Accu-Seal clamps	TAS300
4	M8-1.25 x 25mm socket head cap bolt	91292A148
4	M8-1.25 locknut	94920A500
4	4.5in exhaust tip	61000078 (Chrome) or 61000078-BLK (Black)
4	Exhaust tip barrel clamps	BHM8X079SS00C
1	Heat-reflective wrap-around sleeving	2627K33 - cut to length
1	C7 Corvette rear center plate	110032
2	Cable ties	7130K59

Touring System Only

1	C7 Corvette DS Touring rear section	B87
1	C7 Corvette PS Touring rear section	B88

Track System Only

1	C7 Corvette DS Track rear section	B89
1	C7 Corvette PS Track rear section	B90

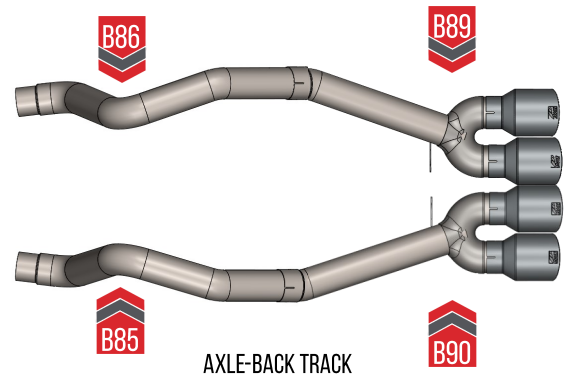
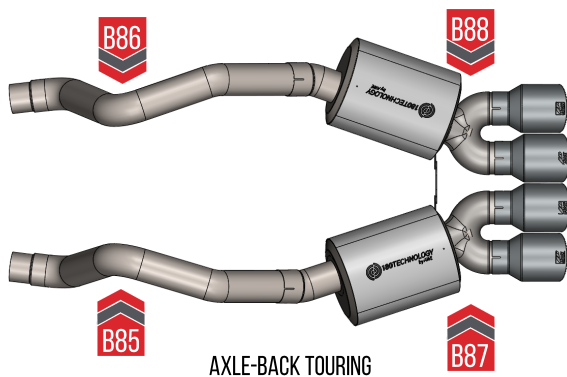



NOTE: Always refer to the manufacturer's service manual for precise torque specifications on all OEM fasteners.



CAUTION: The exhaust may be **VERY HOT** — allow adequate time for the system to cool down before disassembly. Severe burns and injury will occur if skin comes into contact with a hot exhaust system.

STEP 1

Installation of the **AWE Axle Back** exhaust system is the reverse of the OEM exhaust removal.

Start by removing the rear bumper valance by removing the license plate, to access to the two bolts shown in **Figure 1**.

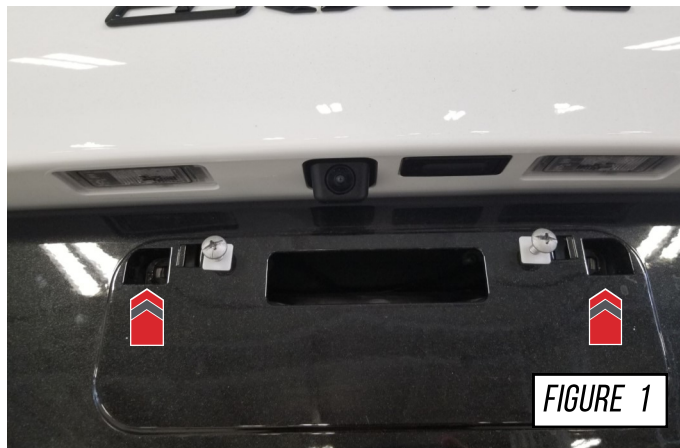

FIGURE 1

STEP 2

Remove the two bolts above the exhaust tip outlets, shown in **Figure 2**.

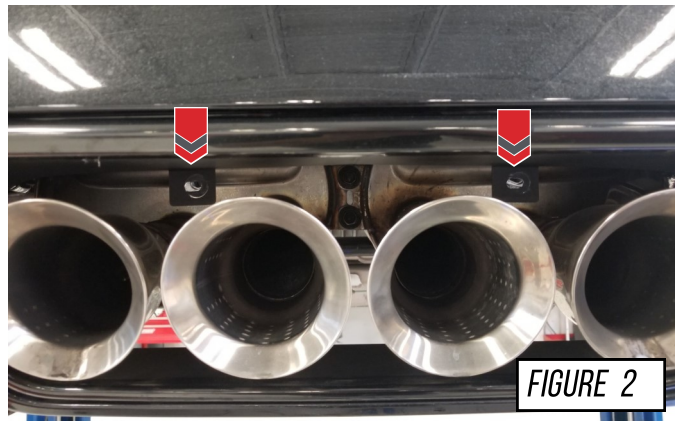

FIGURE 2

STEP 3

Remove the 5 per side screw, shown as **(A)** 10 screws total, found along the bottom of the rear valance, leave the 1 screw per side, shown as **(B)**.



FIGURE 3

STEP 4

Remove the driver and passenger side plastic grill inserts by pushing them out from the inside. These are held into place with 6 clips shown in **Figure 4**.



You may use painters tap to protect the paint, but is not required.



STEP 5

Remove the two rear reflectors shown in **Figure 5-1** by pushing them out from the inside of the bumper. Each one is held in with 3 clips.



With the reflectors out of the way, you now have access to 4 bolts, two on each side to be removed shown in **Figure 5-2**.



STEP 6

Remove the rear valance from the car, this is done by unclipping the top corners and carefully pulling the part away from the car.

STEP 7

For **Non-NPP** exhaust skip this step.

For NPP vehicles, unplug the driver and passenger side rear valve harness wires from the valve motor, shown in **Figure 7**. This can be accomplished by disengaging the grey lock tab and squeezing the harness plug.



STEP 8

Remove the two bolts holding the rear mufflers together, as shown in **Figure 8-1**.

Detach the rear muffler hanger, by removing the two bolts from each side shown in **Figure 8-2**.



Save these hanger bracket bolts as they will be used when installing the new exhaust.

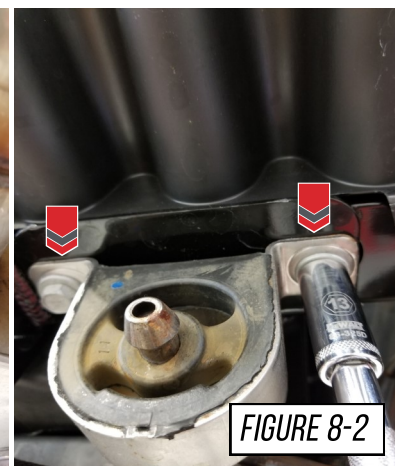

STEP 9

For **Manual** vehicles skip this step.

Automatic vehicles ONLY:

To remove the driver side exhaust tube, you need to shift the vehicle into neutral. This will allow enough space around the shift linkage on the transmission for the exhaust tube to slide out, as shown in **Figure 9**.

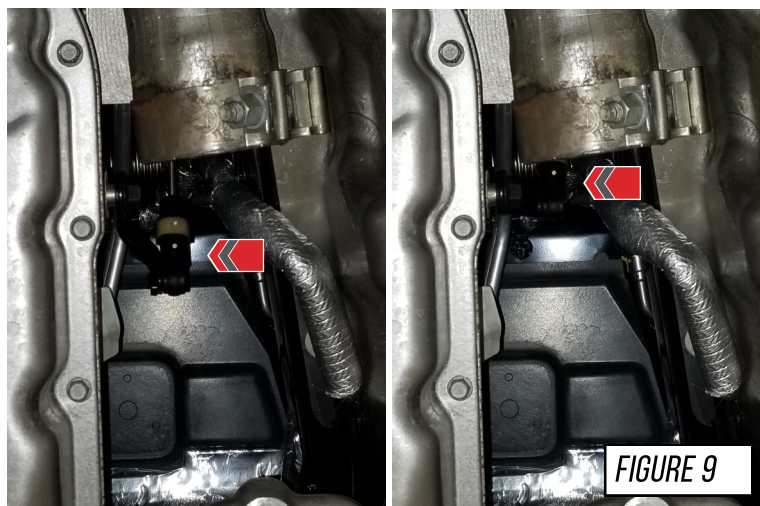

STEP 10

Loosen the driver and passenger clamp bolts, shown in **Figure 10**. This will allow you to remove both rear sections of the exhaust.

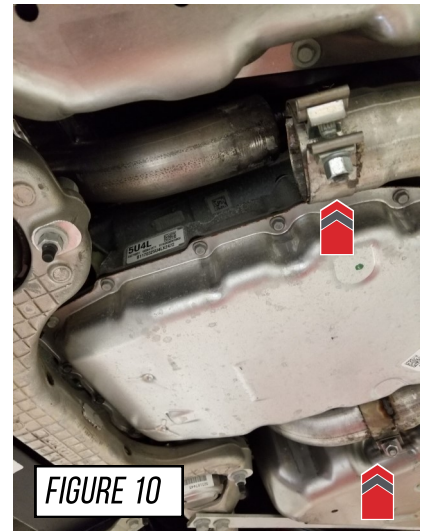

STEP 11

Pivot the driver and passenger side exhaust tubes down from the rear of the vehicle and remove as shown in **Figure 11**.



The exhaust mount on the rear section will need to be removed and reused during the installation of your new exhaust.

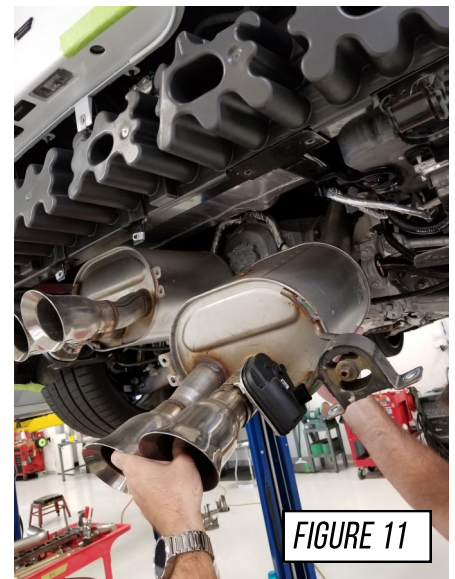

STEP 12

Non-NPP vehicles skip this step.

With all components removed, secure the NPP valve harness to the chassis, with cable ties, as seen in **Figure 12**.



STEP 13

Cut the supplied 10in section of heat wrap in half, as shown in Figure 13-1. Use the heat wrap to cover the braided sections of **DRIVER SIDE** transmission lines shown in **Figure 13-1**. With the heat shield on, use the supplied zip ties to ensure the line is secured out of the way.

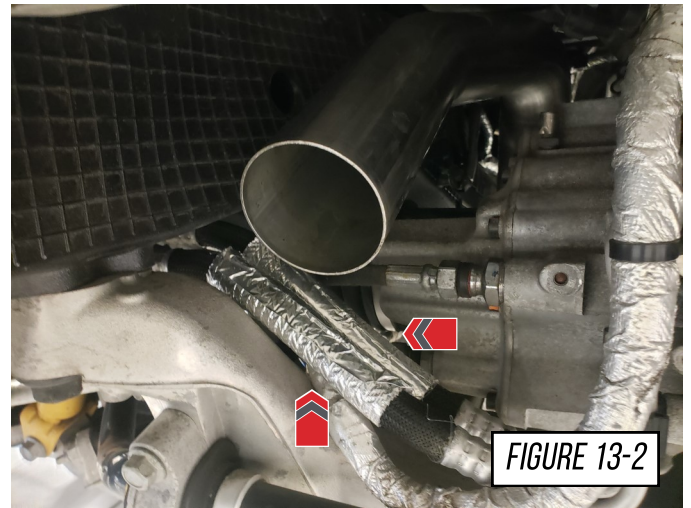
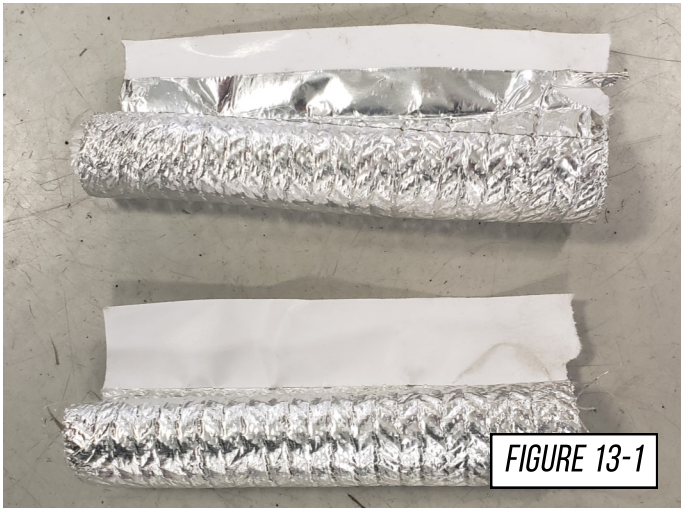

STEP 14

Non-AFM systems skip to the next 3 steps.



AFM car **REQUIRE** the AFM simulators.

Locate and remove the 2 AFM valve motors from the OEM exhaust.

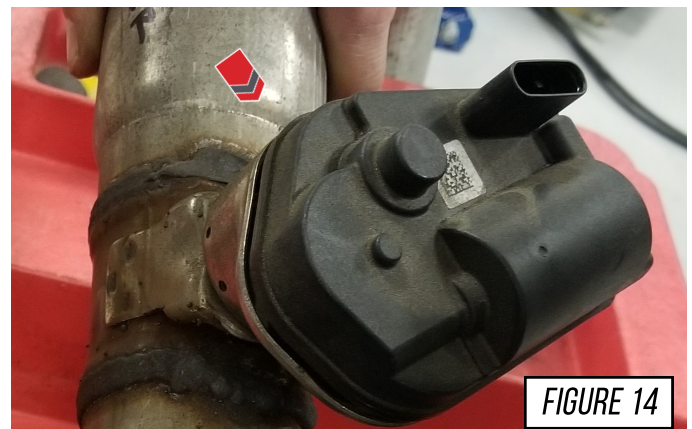

STEP 15

Non-AFM systems skip to the next 2 steps.

Using the factory hardware, bolt both the AFM valve motors to the AWE AFM simulators.

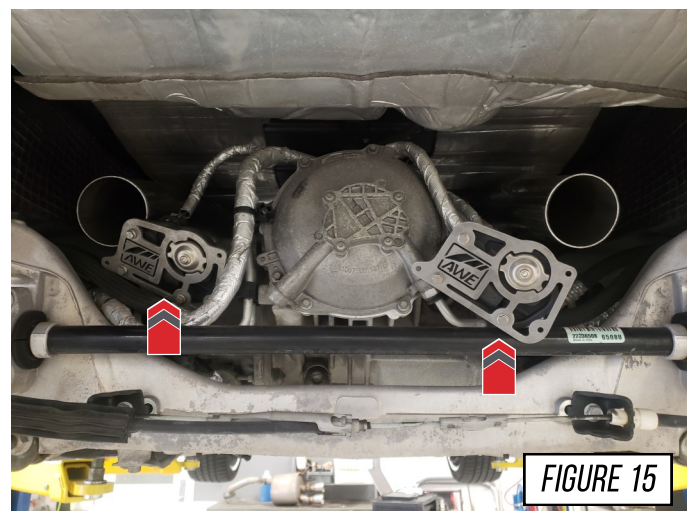

STEP 16

Non-AFM systems skip to the next step.

Plug the both valve motors into the OE harness and safely secure the AWE valve simulator assemblies to the wiring harness over the top of the transaxle.



Make sure to mount the assembly away from any moving parts or high temperature areas.

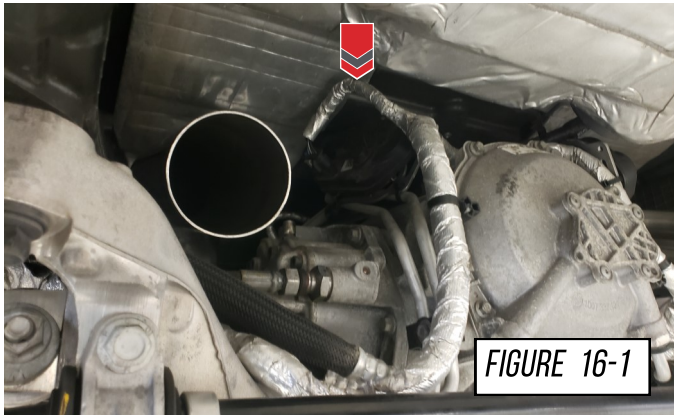

FIGURE 16-1

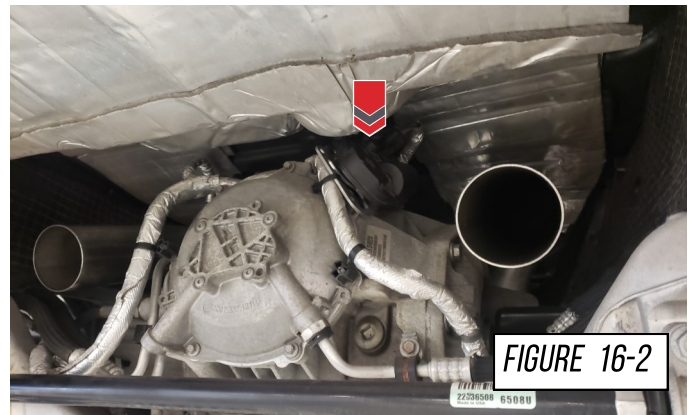
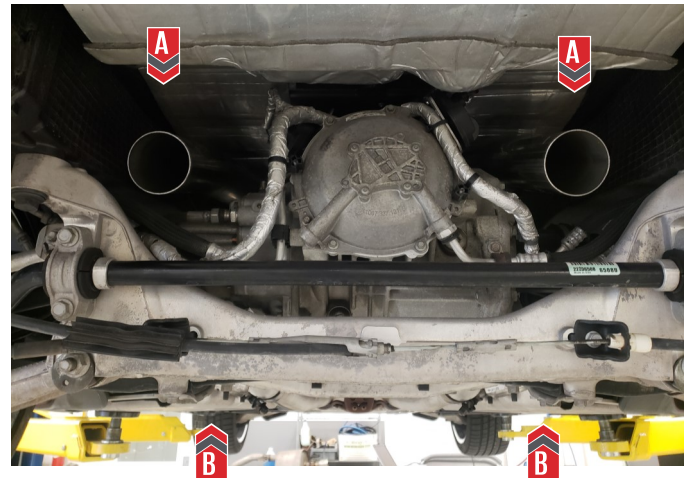

FIGURE 16-2

STEP 17

Install the two over axle tubes from the rear of the vehicle (**A**), following the same way the OE system was removed and connecting to the X pipe (**B**), shown in **Figure 17**.

Ensure you install the driver and passenger tube on the correct side.



STEP 18

Install the factory rear hangers (**B**) and the Accu-Seal clamps onto your AWE driver and passenger side rear sections of the exhaust (**A**), as seen in **Figure 18**.

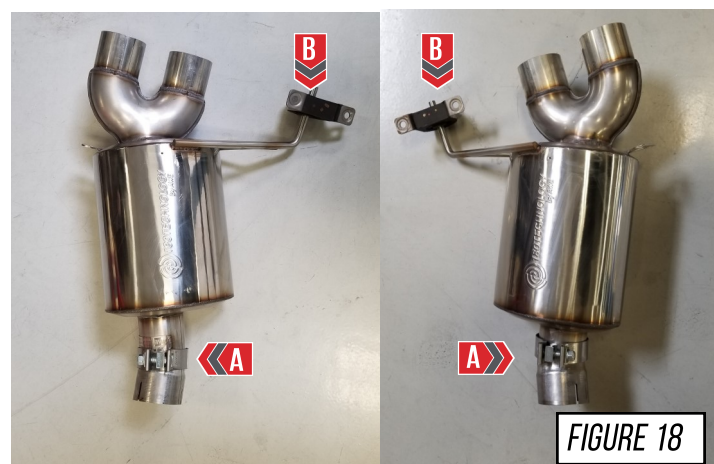

FIGURE 18

STEP 19

It is crucial to install each section and Accu-Seal clamp correctly to prevent loose joints, exhaust leaks between the tubing connections and rattles.

Arrow A in **Figure 19** shows the expanded pipe and the preinstalled Accu-Seal clamp being brought up to the corresponding pipe.

Arrow B in **Figure 19** shows the overlapping pipe installed correctly over the corresponding pipe.

Arrow C in **Figure 19** shows the Accu-Seal clamp being brought to the edge of the expanded pipe.

NOTES:



- **Do not** torque any Accu-Seal clamp until the entire exhaust has been installed and adjusted.
- Torque specification is a minimum of 60 ft/lbs

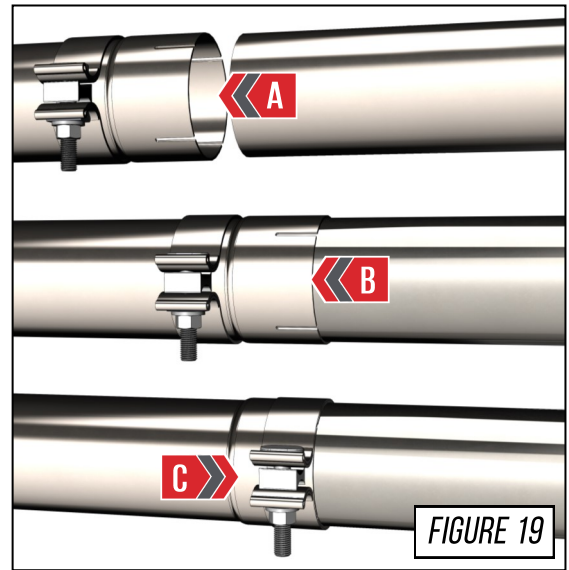

FIGURE 19

STEP 20

Install the rear driver and passenger sections onto the over axle tube, ensure the slip joint is fully pressed together as seen in **Figure 20**. Hand tighten the Accu-seal clamps.

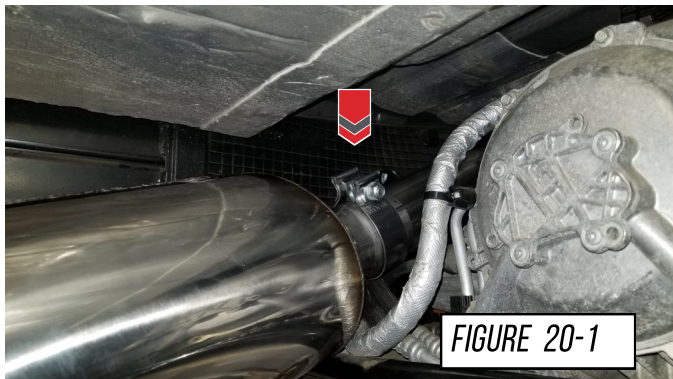

FIGURE 20-1

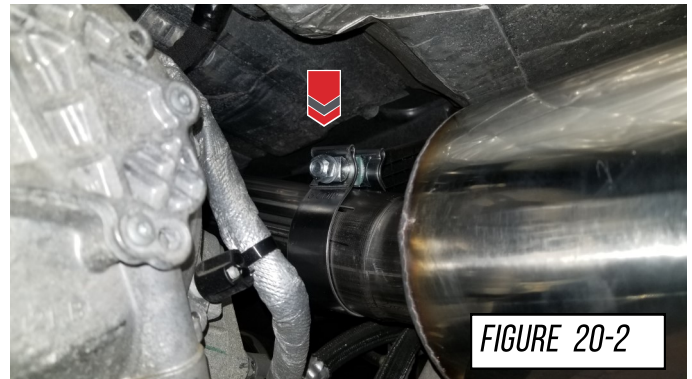

FIGURE 20-2

STEP 21

With the rear sections of the exhaust in place, use the factory hardware you removed earlier to reinstall the rear hangers, as shown in **Figure 21**.

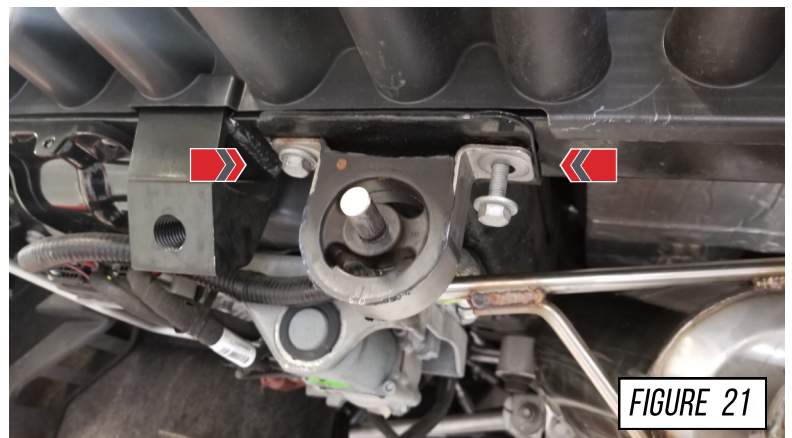

FIGURE 21

STEP 22

With both rear sections in place as shown in **Figure 22-1**, gather the AWE exhaust plate and provided hardware to bolt together the driver and passenger side section with the plate installed towards the rear of the vehicle as shown in **Figure 22-2**.



Hand tighten all bolts first to allow for correct alignment.

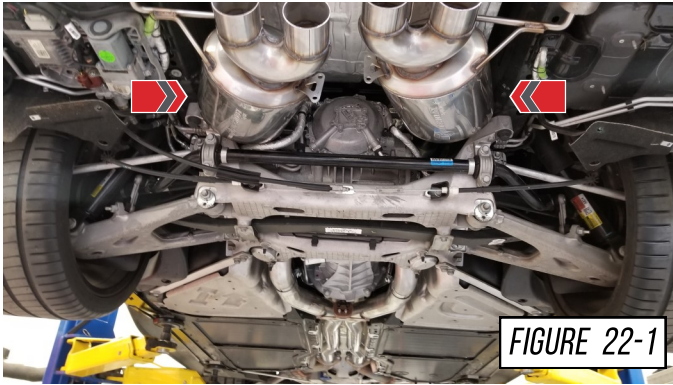

FIGURE 22-1

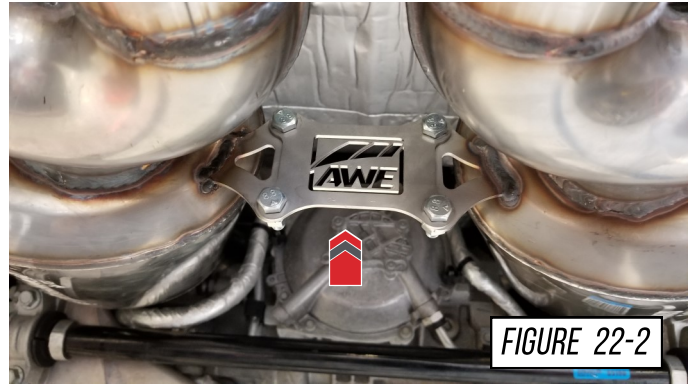

FIGURE 22-2

STEP 23

As mentioned in step 19 and 20, prior to this step all joints and clamps should be snug but not fully tightened down.

Make sure to adjust the orientation of the system so that the exhaust tubes have plenty of clearance from any parts of the chassis, braces, and heat shields. Once the system is oriented correctly, tighten down the clamps as shown in **Figure 23**.



NOTE: To ensure your perfect fitment, take your time to adjust your system properly

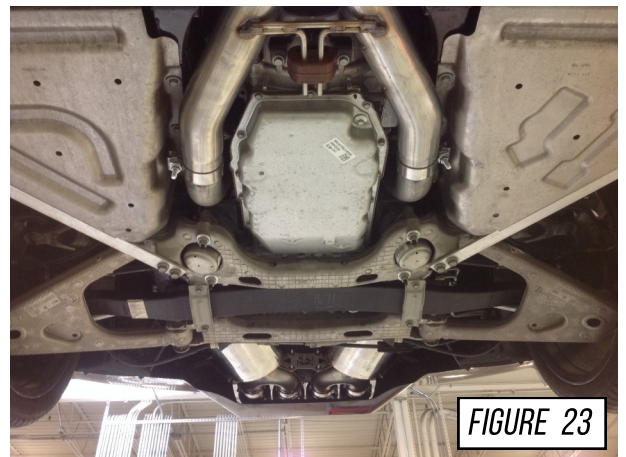

FIGURE 23

STEP 24

Now reinstall the rear bumper sections, this process is the opposite of steps 1 through 6.



Be careful not to scratch the paint on the body.

STEP 25



Make sure to apply anti-seize on all barrel clamp bolts.

Install your four provided AWE exhaust tips, as shown in **Figure 25**. Torque bolts to 18 ft/lbs



STEP 26

For the best tip fitment, align the barrel style tip clamp to cover *only* the slot, shown by **Arrow A**

Torque the tip clamp to 18 ft./lbs.



NOTES:

- It is required to apply anti-seize to the threads to prevent thread binding, shown by **Arrow B**
- It is okay to have the clamp extend beyond the edge of the tip inlet.

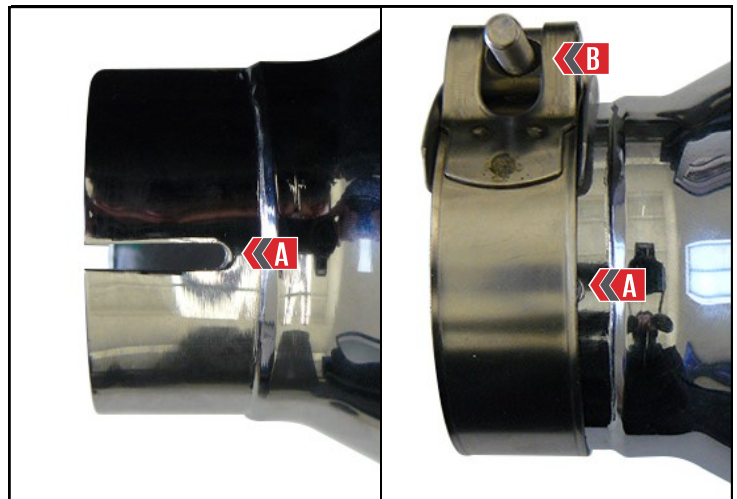

STEP 27

Go back across the exhaust system one last time to check for contact and tighten the Accu-seal clamps. Accu-seal clamps should be tightened to at least 60 ft-lbs and the tubes should be adjusted so that the tips sit evenly in the rear bumper. At this point installation is complete!



ENJOY!



TROUBLESHOOTING

Issue	Solution
Exhaust is not fitting correctly	Most fitment issues are due to improperly adjusted exhaust. This includes tip fitments and rattling due to chassis contact. Check out our fitment guide for more installation tips.
Wrong or missing parts	Double check the parts list for your system and compare them with what you received. Fill out our contact form, found below and let us know what parts you need.

CARE

Once installed properly, your AWE exhaust will provide years of trouble-free performance.

The exhaust volume and sound will settle with usage; 800-1000 miles is required to break-in new exhaust systems.

Also, please note that the rear **180Technology**[®] resonator has a small drain hole to allow condensation to escape. Water drops from this area are normal.

Periodic cleaning of exhaust tips is necessary to maintain proper finish, especially in areas prone to road salt and caustic deicing solutions. Use a mild soap and water solution or car wax to clean the finish. Avoid using abrasive polishes, as they can scratch the finish.

Any questions or comments,
please do not hesitate to contact us:

AWE
199 Precision Drive
Horsham, PA 19044
215-658-1670
CONTACT FORM

WARRANTY

Up-to-date warranty information is found [HERE](#).